

GE Healthcare

# Datex-Ohmeda S/5™ Light Monitor

User's Reference Manual

Referenzhandbuch

Mode d'emploi

Manual de Referencia del Usuario

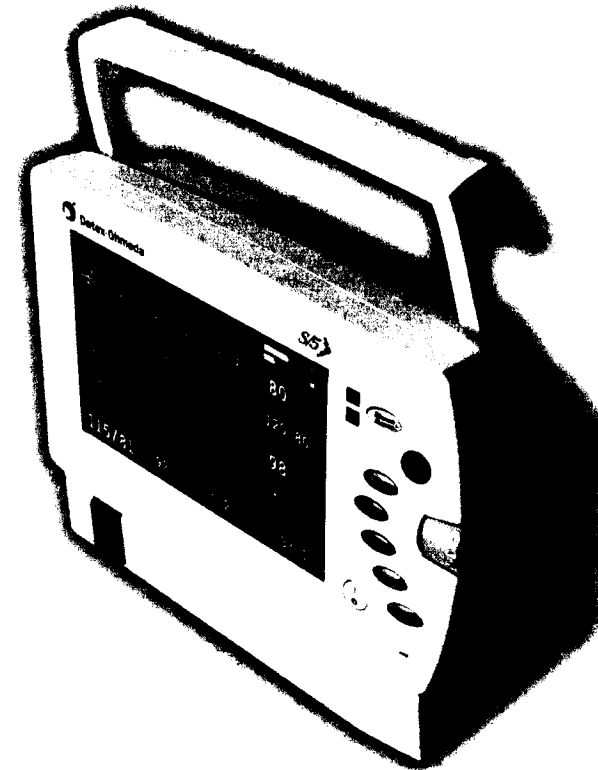

Datex-Ohmeda S/5™ Light Monitor

User's Reference Manual  
Referenzhandbuch

Mode d'emploi  
Manual de Referencia del Usuario



# **Datex-Ohmeda S/5 Light Monitor**

## **User's Reference Manual**



Conformity according to the Council Directive 93/42/EEC concerning medical devices

CAUTION: U.S. Federal and Canadian law restricts this device to sale by or on the order of a licensed medical practitioner. Outside the USA and Canada, check local laws for any restriction that may apply.

Document No. M1037860  
27 October 2005

GE Healthcare Finland Oy  
Helsinki, Finland  
P.O. Box 900  
FI-00031 GE  
Tel: +358 10 39411, Fax: +358 9 1463310

Datex-Ohmeda, Inc.  
P.O. Box 7550, Madison  
WI 53707-7550, USA  
Tel. +1-608-221-1551  
Fax +1-608-222-9147

[www.gehealthcare.com](http://www.gehealthcare.com)

© 2005 General Electric Company. All rights reserved

### Intended purpose

Datex-Ohmeda S/5 Light Monitor, F-LM1, F-LMP1 is intended for stationary and mobile monitoring of patient's ECG, SpO<sub>2</sub>, body temperature, invasive and non-invasive blood pressures as well as respiration and CO<sub>2</sub> in hospitals and ambulances. When used outdoors, the monitor must be in the protective case. The monitor is intended for use by qualified medical personnel only. The Light Monitor is intended for patients with weight of 5 kg (11 lb) or more. Respiration monitoring is intended for patients three years old and up.

### Classification according to IEC 60601-1

- CLASS I EQUIPMENT and INTERNALLY POWERED EQUIPMENT according to the type of protection against electrical shock.
- TYPE BF or CF equipment according to the degree of protection against electric shock is indicated with a symbol beside each patient connector.
- Degree of protection against harmful ingress of water as detailed in the IEC 60529: Monitor: IPX1, vertically falling water drops shall have no harmful effects (applicable when the monitor is in upright position, or tilted backwards). In the protective case IPX4, splash proof, when the case is closed properly, the monitor is intact and operates on battery power. Power adapter: IPX0, ordinary equipment.
- EQUIPMENT not suitable for use in the presence of a FLAMMABLE ANESTHETIC MIXTURE with air or with oxygen or nitrous oxide.
- CONTINUOUS OPERATION according to the mode of operation.
- CSPR 11: Group 1, Class A

### Classification according to EU Medical Device Directive

- The monitor is classified as IIb.

### Responsibility of the manufacturer

GE Healthcare Finland Oy is responsible for the effects on safety, reliability and performance of the equipment only if:

- assembly, operations, extensions, readjustments, modifications, service and repairs are carried out by authorized personnel.
- the electrical installation of the relevant room complies with appropriate requirements.
- the equipment is used in accordance with this manual.

The CO<sub>2</sub> measuring option (N-LCM) is manufactured for GE Healthcare Finland Oy by Pryon Corp., 8500 S.W. Creekside Place, Beaverton, OR 97008-7107 USA.

### Trademarks

Datex, Ohmeda, S/5, MemCard, ComWheel and Oxytip+ are trademarks of GE Healthcare Finland Oy. All other product and company names are property of their respective owners.

## Table of contents

<b>1</b>	<b>How to use this manual</b>	<b>1</b>
	Related documents	1
	Symbols and abbreviations	2
	Symbols on the equipment	2
	Symbols used in this manual	6
	Chapter symbols	6
	Abbreviations	7
	Conventions used in this manual	8
<b>2</b>	<b>Safety</b>	<b>9</b>
	Warnings	9
	EXPLOSION HAZARD	9
	ELECTRICAL SHOCK HAZARD	9
	PATIENT SAFETY	10
	Cautions	11
	BATTERY CAUTIONS	12
	Points to note	12
<b>3</b>	<b>Unpacking and installation</b>	<b>15</b>
	Unpacking	15
	Placing	15
	ESD precautionary procedures	16
	Electrical Power Adapter	17
	Charge batteries	18
	Connecting to network	18
	Configuration	18
	Disposal	18
<b>4</b>	<b>Description</b>	<b>19</b>
	Parts of the monitor	19
	Rear panel	20
	Keys and controls	21
	ComWheel	21
	Display	22
	Measurement connectors	22
<b>5</b>	<b>Operation</b>	<b>25</b>
	Getting started	25
	During monitoring	25
	In-between patients	25
	At the end of the day	25
	Using menus	26

<b>6 Batteries</b>	<b>29</b>
Charging batteries	29
Charging in the monitor	29
Removing batteries from the Battery Module	30
Battery alarms	30
Battery Maintenance	30
Storing and disposing of batteries	31
<b>7 Care and cleaning</b>	<b>33</b>
Cleaning	33
Dust filter	34
Monitor casing	34
Pulse oximetry sensors	34
ECG cables, temperature probes, NIBP hose	35
NIBP cuff	35
Invasive pressure cables	35
Airway accessories	35
Safety checks for software	36
Regular checks	36
ECG, Impedance respiration	36
Pulse oximetry	36
Temperature	36
InvBP	37
NIBP	37
CO2	37
Functioning of the alarms	37
<b>8 Alarms</b>	<b>39</b>
Alarm categories	39
Smart start alarms	40
Silencing alarms	41
Silencing alarms for two minutes	41
Turning audible alarms on and off	41
Alarm messages	42
Alarms setup and adjustments	42
Adjusting alarm limits	43
Other settings	44
Automatic alarm recording	44
Alarm tables	44
Alarm sources	44
Default limits	45
Auto alarm limits	47

<b>9 Monitor setup</b>	<b>51</b>
Screen setup	51
Selecting waveforms	52
Selecting numerical display fields	53
Setting time & date	53
Adjusting the display brightness	54
Install/Service menu	54
Default settings	54
<b>10 Trends</b>	<b>61</b>
Viewing graphic trends	62
Graphic trend pages	62
Viewing numerical trend	64
Changing trend setup	66
Erasing trend data	66
<b>11 Patient data</b>	<b>67</b>
<b>12 Recording and printing</b>	<b>69</b>
Recording	69
Selecting the waveforms to be recorded	69
Recording trends	70
Other recorder settings	70
Recorder paper replacement	71
Printing	71
Selecting the printer	71
Selecting the paper size	72
Printer installation	72
Printer setup	72
<b>13 Network and DataCard</b>	<b>73</b>
Networking	73
Patient view and multi view on the Datex-Ohmeda Central screen	73
Monitor-to-Monitor communication	74
DataCard	74
Inserting and removing the card	74
Collecting data	75
<b>14 ECG</b>	<b>77</b>
Monitoring ECG	77
Applying electrodes	77
Patient preparation	77
Placing electrodes	78
Electrode coding	78
Selecting trunk cable	79

What should happen when electrodes are applied? .....	79
Selecting ECG lead .....	79
ECG display .....	79
Cascaded ECG .....	80
ECG adjustments .....	80
ECG setup .....	81
Setting heart rate alarm .....	82
Pacemaker patients .....	82
<b>15 Respiration .....</b>	<b>83</b>
Monitoring respiration .....	83
Patient connections .....	83
Respiration setup .....	83
Limitations of measuring .....	84
Measuring principle .....	85
<b>16 Pulse oximetry .....</b>	<b>87</b>
Monitoring pulse oximetry .....	87
Selecting sensor .....	88
Applying sensors .....	88
What should happen when sensor is applied? .....	88
Pulse oximetry display .....	89
Measuring limitations .....	89
Adjustments .....	90
Setting SpO2 alarms .....	91
Measuring principle .....	91
<b>17 Temperature .....</b>	<b>93</b>
Monitoring temperature .....	93
Temperature display .....	93
Temperature testing .....	93
Temperature setup .....	93
<b>18 Non-invasive blood pressure (NIBP) .....</b>	<b>95</b>
Monitoring NIBP .....	95
Display of NIBP measurement .....	96
Automatic NIBP double check .....	97
Using NIBP functions .....	97
Starting/Stopping autocyte .....	98
Starting a manual measurement .....	98
Canceling any measurement .....	98
Starting a continuous measurement (STAT) .....	99
Using venous stasis .....	99
NIBP adjustments .....	100
Calibration check .....	101

NIBP alarms .....	101
Measuring principle .....	101
<b>19 Invasive blood pressure .....</b>	<b>103</b>
Monitoring invasive pressures .....	103
Preparing pressure line .....	103
Zeroing transducer .....	104
Invasive pressure display .....	105
Adjustments .....	105
Labeling the invasive line .....	106
Changing the scale .....	107
Other invasive pressure setup adjustments .....	107
Invasive pressure alarms .....	108
Measuring principle .....	108
<b>20 Carbon dioxide, CO2 .....</b>	<b>109</b>
Monitoring mainstream CO2 .....	109
Display of CO2 measurement .....	111
CO2 adjustments .....	111
Calibration check .....	112
Unit conversions .....	112
Measuring principle .....	112
<b>21 Maintenance and troubleshooting .....</b>	<b>113</b>
Maintenance .....	113
Once a month .....	113
Once a year .....	113
Checklist .....	113
General .....	113
ECG/Respiration .....	114
Pulse oximetry .....	114
Temperature .....	114
Non-invasive blood pressure NIBP .....	115
Invasive blood pressure .....	115
CO2 .....	116
Battery packs and Module .....	116
Alarm and information messages .....	117
ECG .....	117
Impedance respiration .....	118
Invasive blood pressure .....	119
NIBP .....	120
Temperature .....	122
Pulse oximetry .....	122
CO2 .....	123

Table of contents

DataCard .....	124
Battery .....	125
Recorder .....	125
Other messages .....	126
Troubleshooting .....	127
<b>22 General specifications</b> .....	<b>129</b>
Parameter specifications .....	129
Alarms .....	136
Option codes .....	137
Nurse call and defibrillator synchronization signals .....	138
<b>23 Accessories</b> .....	<b>139</b>
Gas monitoring .....	139
Mainstream CO2 accessories .....	139
Calibration gases .....	140
Pulse oximetry sensors .....	140
Reusable sensors .....	140
Cables for reusable sensors .....	141
Universal sensors (cable required) .....	141
Single-patient sensors (cable required) .....	141
Cable for universal & single-patient sensors .....	141
ECG cables .....	142
ECG trunk cables, IEC color coding .....	142
ECG lead sets, IEC color coding .....	142
ECG trunk cables, AAMI color coding .....	143
ECG lead sets, AAMI color coding .....	143
ECG replacement clip leads .....	144
ECG replacement snap leads .....	145
ECG miscellaneous .....	145
Compatibility Trunk cables .....	145
Multi-Link Leadsets with Grabber in IEC color coding .....	145
Multi-Link Leadsets with Snaps in IEC color coding .....	146
Multi-Link Leadsets with Grabber in AAMI/AHA color coding .....	146
Multi-Link Leadsets with Snaps in AAMI/AHA color coding .....	146
Electrodes .....	147
Temperature probes .....	147
Reusable probes .....	147
Disposable probes .....	147
NIBP cuffs .....	148
Latex-free reusable .....	148
NIBP cuffs, disposable .....	149
NIBP cuff hoses .....	149
Invasive blood pressure transducers .....	149

InvBP transducers and cables, reusable .....	150
Flushing kits, disposable .....	150
Interface cables .....	150
Interface cables for configured monitors .....	150
Mounting elements .....	151
Miscellaneous .....	151
Accessory kits .....	152

**General**

1 How to use this manual .....	1
2 Safety .....	9
3 Unpacking and Installation .....	15

## 1 How to use this manual

This manual describes how to use and maintain the Datex-Ohmeda S/5 Light Monitors F-LM1 and F-LMP1.

The **General** section gives you information about safety aspects and installation. Get acquainted with them before using the monitor.

The **Basic Operation** section helps you through the daily basic use of the monitor.

The **Detailed Operation** section describes the monitor functions in detail. These chapters are necessary if you want to master all the features available in the monitor.

The **Troubleshooting/Specifications and Index** sections help you find the information you need in various situations.

The **Accessories** list provides information on the supplies and accessories available for the monitor.

**NOTE:** Before using your monitor, please read this manual. Pay special attention to **WARNING** and **CAUTION** statements.

## Related documents

### S/5 Light Monitor Technical Reference Manual

The Technical Reference Manual provides detailed technical descriptions and instructions for the service, maintenance procedures and troubleshooting.



## Symbols and abbreviations

### Symbols on the equipment



Attention, consult accompanying documents.

on the rear panel indicates the warning:

Electric shock hazard. Do not open monitor frame. Refer servicing to qualified personnel. Do not touch any part of the monitor or patient connections during defibrillation procedure. Disconnect power supply before servicing. Use only external power adapter N-LPOW.

on the rear panel dust filter indicates the reminder:

Check rear panel dust filter regularly, and clean at least once a month.

on the patient connector panel indicates the warnings and cautions:

Use only the specified cables and accessories. Ensure proper contact of the return electrode of the electrosurgery unit to your patient to avoid possible burns at ECG electrode or other probe sites. The output signals are not floating and must not be connected directly to a patient.

on the external power adapter indicates the cautions:

For continued protection against fire hazard, replace only with same type and rating of fuse. Make sure voltage selector is set according to local voltage. For indoor use only. For patient transport outdoors, use the monitor in its protective case and with battery power only. Do not immerse in liquid or allow any liquid to enter the interior.

on the battery unit indicates the warnings and cautions:

Do not put in fire. Do not short-circuit any terminals. Do not disassemble or mutilate. Use only with Battery Module or External Battery Charger. Discharge and charge batteries fully once a month to restore full capacity. Sealed NiCd battery must be recycled or disposed of properly. Discharge before disposing.

on the CO<sub>2</sub> sensor:

Do not immerse the sensor in liquids or autoclave it.



SpO<sub>2</sub>, CO<sub>2</sub>: Type BF (IEC-60601-1) protection against electrical shock, not defibrillation proof.



NIBP: Type BF (IEC-60601-1) defibrillator-proof protection against electrical shock.



Temperature: Type CF (IEC-60601-1) protection against electrical shock.



ECG, Impedance Respiration, P<sub>1</sub>, P<sub>2</sub>: Type CF (IEC-60601-1) defibrillator-proof protection against electrical shock.

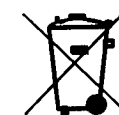

Ni-Cd

Battery packs contain heavy metal cadmium (chemical symbol Cd) and in case of disposal, must be separated from other waste according to local regulations.

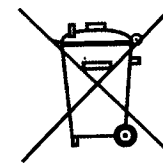

This symbol indicates that the waste of electrical and electronic equipment must not be disposed as unsorted municipal waste and must be collected separately. Please contact an authorized representative of the manufacturer for information concerning the decommissioning of your equipment.

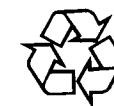

Ni-Cd

Battery packs contain Ni-Cd and they can be recycled.

IPX-class: Degree of protection against harmful ingress of water as detailed in the IEC 60529:

IPX0 - ordinary equipment

IPX1 - vertically falling water drops shall have no harmful effects

IPX4 - splash proof



Battery charging LEDs: LEDs are blinking while batteries are being charged and stay illuminated when batteries are fully charged and the monitor is connected to mains.



The monitor is connected to the network (optional).



The DataCard (option) is inserted. If symbol is blinking, the card is faulty or it is not inserted properly.



A blinking heart next to the heart rate or pulse rate value indicates the beats detected.



A lung next to the respiration rate value indicates that respiration rate is calculated from the impedance respiration measurement.



Silence alarm indicator. When displayed on the upper left corner of the screen, indicates that all the alarms are silenced. When in the menu or digit fields, indicates that the alarm source has been turned off.



Alternating current



Input voltage



Output voltage



Ethernet connectors



Printer connector

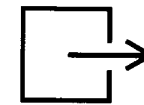

Sample gas outlet



Do not immerse the sensor in liquids.



ESD warning symbol for electrostatic sensitive devices. Pins of connectors identified with the ESD warning symbol should not be touched. Connections should not be made to these connectors unless ESD precautionary procedures are used. See "ESD precautionary procedures" in section "Unpacking and installation" for details.



Symbol for non-ionizing electromagnetic radiation. Interference may occur in the vicinity of equipment marked with this symbol.

**Symbols used in this manual**

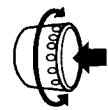

Indicates the procedure for making adjustments (turn and press) in the menus.



Submenu. Selecting a menu item with this symbol opens a new menu.

**Chapter symbols**

**General chapters**



General information



Operation



Alarms



Trends



Recorder

**Measuring parameter chapters**



ECG



NIBP

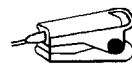

Pulse oximetry



Temperature



Invasive pressure

**General chapters**



Monitor setup

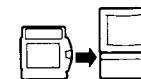

Networking and DataCard



Patient data

**Measuring parameter chapters**



CO<sub>2</sub>



Impedance respiration

**Abbreviations**

**Blood pressure:**

Art	arterial pressure
CVP	central venous pressure
ICP	intracranial pressure
Inv.	invasive
Mean	mean of diastolic and systolic pressures
NIBP	non-invasive blood pressure
P	blood pressure
PA	pulmonary arterial pressure
S/D	systolic/diastolic

**Temperature:**

Temp	temperature
AirW	airway temperature
Axil	axillary temperature
Blad	bladder temperature
Eso	esophageal temperature
Myo	myocardial temperature
Naso	nasopharyngeal temperature
Rect	rectal temperature
Room	room temperature
Skin	skin temperature
Temp	temperature
Tymp	tympanic temperature

Core	central temperature
Surf	surface temperature
<b>Miscellaneous:</b>	
Casc	cascaded ECG waveform
CISPR	International Special Committee on Radio Interference
ECG	electrocardiography
EL	electroluminescence (display)
EMC	electromagnetic compatibility
ESD	electrostatic discharge
HR	heart rate
LED	light emitting diode
Pleth	plethysmograph waveform
P/N	part number
PR	pulse rate
RF	radio frequency
SpO <sub>2</sub>	oxygen saturation measured by pulse oximeter
MS	mainstream CO <sub>2</sub> measurement
SN, S/N	serial number

### Conventions used in this manual

Names of the keys appear in bold typeface: **Normal Screen**.

Selectable menu items appear in bold and italic typeface: ***Previous Menu***.

Informative messages displayed on the screen are enclosed in single quotes: 'Please wait'.

## 2 Safety

### Warnings

#### WARNING

**Indicates situations in which the user or the patient may be in danger of injury or death.**

#### EXPLOSION HAZARD

- Do not use the monitor in presence of flammable anesthetics.

#### ELECTRICAL SHOCK HAZARD

- Do not remove cover. Refer servicing to qualified service personnel.
- Use only hospital-grade grounded electrical outlets and power cord.
- Grounding reliability can only be achieved when the equipment is connected to a receptacle marked 'hospital grade'.
- Make sure that external equipment is hospital grade grounded before you connect it to the monitor. Do not connect any external equipment to the monitor, except that specified by Datex-Ohmeda.
- When connecting external equipment to monitor, make sure that the whole combination complies with safety standard IEC 60601-1-1 for the medical electrical systems and with the requirements of local authorities. A non-medical electrical equipment connected to monitor shall be supplied from an extra separating transformer with a protectively grounded power outlet.
- Before cleaning, disconnect the monitor from electrical outlet.
- Do not immerse any part of the monitor in liquids or allow liquid to enter the interior.
- Do not autoclave any part of the monitor with steam or ethylene oxide.
- After cleaning, or if liquid has accidentally entered the interior of the monitor, make sure that every part of the monitor is dry before reconnecting it to the power supply.

## PATIENT SAFETY

- Always make sure that necessary alarm limits are set and operative when you start monitoring.
- When the alarms are suppressed, observe the patient frequently.
- Connect only one patient to one monitor at a time.
- Constant attention by a qualified professional is needed whenever a patient is under anesthesia or connected to a ventilator. Some equipment malfunctions may pass unnoticed in spite of the monitor alarm.
- Do not use antistatic or electrically conductive breathing tubes. They may increase the risk of burns when electrosurgery unit is utilized.
- Do not use the monitor during magnetic resonance imaging (MRI).
- ECG, Impedance Respiration, InvBP: Ensure proper contact of the return electrode of the electrosurgery unit to your patient to avoid possible burns at sensor sites.
- ECG, Impedance Respiration, InvBP: Make sure that no part of the patient connections touches any electrically conductive material including earth.
- Impedance Respiration: In obstructive apnea, thoracic movements and impedance variations may continue.
- NIBP: The monitor sets the inflation pressure automatically according to the first measurement. Reset the case to reset the inflation limit before measuring a new patient.
- PATIENTS WITH PACEMAKERS OR ARRHYTHMIAS: Monitor may count the pacemaker pulses as heart beats during cardiac arrest, some arrhythmias, and with certain types of pacemakers particularly in **ON R** mode. Do not rely entirely upon rate meter alarms. Keep patients with pacemakers and arrhythmias under close surveillance.
- PACEMAKER PATIENTS: The impedance respiration measurement may cause rate changes in Minute Ventilation Rate Responsive Pacemakers. Set the pacemaker rate responsive mode off or turn off the impedance respiration measurement on the monitor.
- SpO<sub>2</sub>: A damaged sensor or a sensor soaked in liquid may cause burns during electrosurgery.

- SpO<sub>2</sub>: Change measuring site frequently. Change the sensor site and check skin and circulatory status every 2-4 hours with adults and every hour with small children.
- The output signals are not floating and must not be connected directly to a patient.
- Do not use delayed analog signals for defibrillator or intra-aortic balloon pump synchronization.
- The monitor is intended for use by qualified medical personnel only.
- InvBP: All invasive procedures involve risks to the patient. Use aseptic technique. Follow catheter manufacturer's instructions.
- InvBP: Use only defibrillator proof cables and transducers.
- Operation of the monitor outside the specified values may cause inaccurate results.
- The monitor or its components should not be used adjacent to or stacked with other equipment. If adjacent or stacked use is necessary, the monitor and its components should be observed to verify normal operation in the configuration in which it will be used.

## Cautions

### CAUTION

Indicates situations in which the unit or devices connected to it may be damaged.

- Use licensed patient cables and accessories only, see the "Accessories" list. Other cables and accessories may damage the system or interfere with measurement.
- Before connecting the power cord, ensure that the input voltage selector is set correctly in the external power adapter.
- Use the monitor outdoors with the battery power only.
- Do not store the monitor beyond the specified temperature range.
- Do not use hypochlorite, ammonia-, phenol- or acetone-based cleaners. They may damage the monitor.
- Clean rear panel fan dust filter once a month or whenever needed.
- Leave space around the monitor for ventilation to prevent the monitor from overheating.

- Do not apply pressurized air to any outlet or tubing connected to the monitor. Pressure may destroy sensitive elements.
- When used in moving vehicle, mount the monitor properly.
- Dispose of the device and parts thereof in accordance with local regulations.
- Vibrations during transport may disturb SpO<sub>2</sub>, ECG, impedance respiration and NIBP measurements.
- CO<sub>2</sub>, SpO<sub>2</sub>: Do not apply force to sensors or sensor cables.
- DataCards: Do not subject cards to excessive heat, bending, or magnetic fields.
- InvBP: Mechanical shock to invasive blood pressure transducer may cause severe shifts in zero balance and calibration and produce erroneous readings.
- Electromagnetic interference from radio-frequency transmitting devices in ambulances may affect the performance of this medical device.

#### BATTERY CAUTIONS

- Do not put in fire.
- Do not short-circuit any terminals.
- Do not use damaged or leaking batteries.
- Do not disassemble or break the batteries.
- Use only with Battery Module or External Battery Charger.
- Charge and discharge batteries fully every three months to restore full capacity.
- Sealed NiCd battery must be recycled or disposed of properly. Discharge before disposing.

#### Points to note

- Medical electrical equipment needs special precautions regarding electromagnetic compatibility and needs to be installed and put into service according to the electromagnetic compatibility information provided in the "Technical Reference Manual" by qualified personnel.
- Portable and mobile RF communications equipment can affect the medical electrical equipment.
- The allowed cables, transducers and accessories for the system are listed in the "Accessories" list later in this manual.

- The equipment is suitable for use in the presence of electrosurgery. Please notice the possible limitations in the parameter sections and in the "Safety precautions" section.
- Service and reparations are allowed for authorized service personnel only.
- CISPR 11 classifications:
  - Group 1 contains all ISM (Industrial, scientific and medical) equipment in which there is intentionally generated and/or used conductively coupled radio-frequency energy which is necessary for the internal functioning of the equipment itself.
  - Class A equipment is suitable for use in all establishments other than domestic and those directly connected to the public low-voltage power supply network that supplies buildings used for domestic purposes.

For your notes:

### 3 Unpacking and installation

#### Unpacking

The monitor is delivered in one box containing typically (as minimum):

- Datex-Ohmeda S/5 Light Monitor
- Datex-Ohmeda S/5 Light Monitor Power Adapter with power cord
- User's Reference Manual

Check that the contents correspond to your order and that all additional options you have ordered are included. If any of the items appears damaged or is missing, contact your sales person immediately.

#### Placing

The monitor can be placed on a flat surface or hung with the handle from bed or wall rails. Make sure that the surface or rail holds up to at least 10 kg/22 lb.

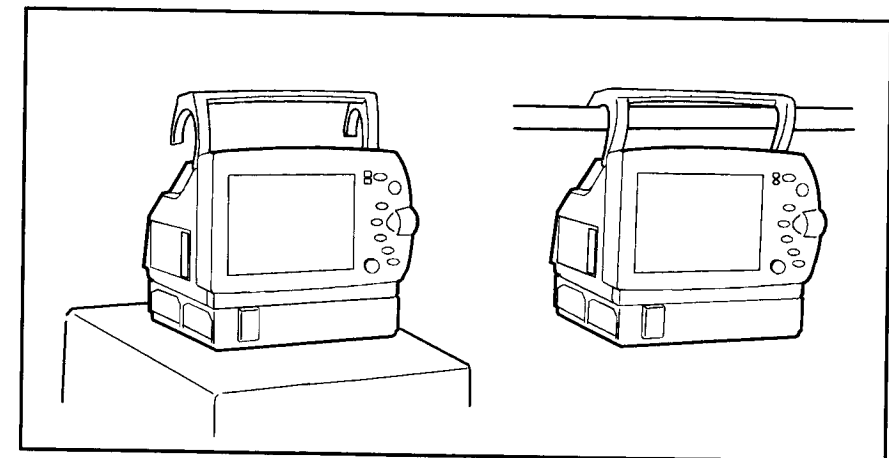

3-1 Installation

A protective case is also available. If using the case, make sure that the monitor is always in a standing position to ensure proper ventilation. The monitor is splash-proof (IPX4) when it is in the protective case and all the openings of the case are closed properly. Make sure the monitor is intact and operates on battery

power. When used outdoors, the monitor must be in the protective case.

NOTE: The pocket in the protective case is not water-proof. Do not place items in the pocket that may be damaged by moisture.

Universal mounting solutions are sold separately. Contact your local distributor.

The monitor or its components should not be used adjacent to or stacked with other equipment. If adjacent or stacked use is necessary, the monitor and its components should be observed to verify normal operation in the configuration in which it will be used.

### ESD precautionary procedures

To avoid electrostatic charges to build up, it is recommended to store, maintain and use the components at a relative humidity of 30% or greater. Floors should be covered by ESD dissipative carpets or similar. Non-synthetic clothing should be used when working with the component. - To prevent applying a possible electrostatic discharge to the ESD sensitive parts of the component, one should touch the metallic frame of the component or to a large metal object located close to the component. When working with the component and specifically when the ESD sensitive parts of the component may be touched, a grounded wrist strap intended for use with ESD sensitive equipment should be worn. Refer documentation provided with the wrist straps for details of proper use.

It is recommended that all potential users receive an explanation of the ESD warning symbol and training in ESD precautionary procedures.

The minimum content of an ESD precautionary procedure training should include an introduction to the physics of electrostatic charge, the voltage levels that can occur in normal practice and the damage that can be done to electronic components if they are touched by an operator who is electrostatically charged. Further, an explanation should be given of methods to prevent build-up of electrostatic charge and how and why to discharge one's body to earth or to the frame of the equipment or bond oneself by means of a wrist strap to the equipment or the earth prior to making a connection.

### Electrical Power Adapter

Use only the power cord and power adapter provided with the monitor.

- Set the voltage selector on the adapter to the right position (115V/230V) e.g. with a pen.
- Connect the adapter cord to the connector on the rear panel.
- Connect the power cord to the adapter and then plug onto the wall electrical outlet.

NOTE: To use the power adapter, it must be lying on a flat surface or hanging from the holder. Do not let any liquid enter the adapter. When external power supply is in use, a green led is lit.

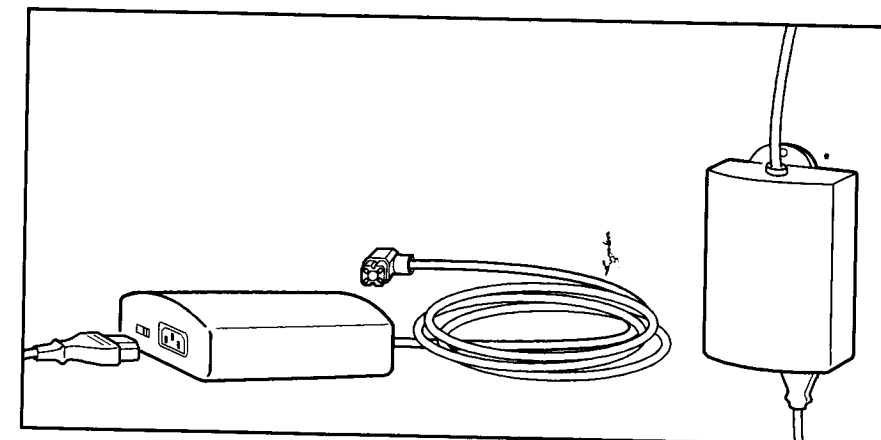

3-2 Placing Power Adapter

#### WARNING

**ELECTRICAL SHOCK HAZARD: Use only hospital grade grounded electrical outlets.**



#### CAUTION

Before connecting the power cord, ensure that the input voltage selector is set correctly in the power adapter.

#### CAUTION

Electromagnetic interference from radio-frequency transmitting devices in ambulances may affect the performance of this medical device.



## Charge batteries

Keep the monitor connected to the mains outlet. The batteries are fully charged when the battery capacity indicators on the screen show FULL and green LEDs in the Battery Module stop flashing.

### CAUTION

When stored for longer periods, or used mostly with mains power, charge and discharge the batteries fully every three months.

## Connecting to network

The monitor can be connected to a monitor network for central monitoring and printing services.

- Connect the Ethernet and location ID plug to the corresponding connectors on the monitor's rear panel.
- Configure the location IDs in the Datex-Ohmeda Central.

When the monitor is connected to the network and turned on, the network symbol is displayed on the upper right corner of the screen:



## Configuration

When the monitor is delivered, it is configured with the factory default settings and is ready to use.

If you want to change the settings and make your own permanent configuration, refer to chapters "Alarms" and "Monitor setup" of this manual.

## Disposal

Dispose of the monitor, parts of it and its packing material in accordance with local environmental and waste disposal regulations.

## Basic Operation

4 Description .....	19
5 Operation .....	25
6 Batteries .....	29
7 Cleaning.....	33

## 4 Description

### Parts of the monitor

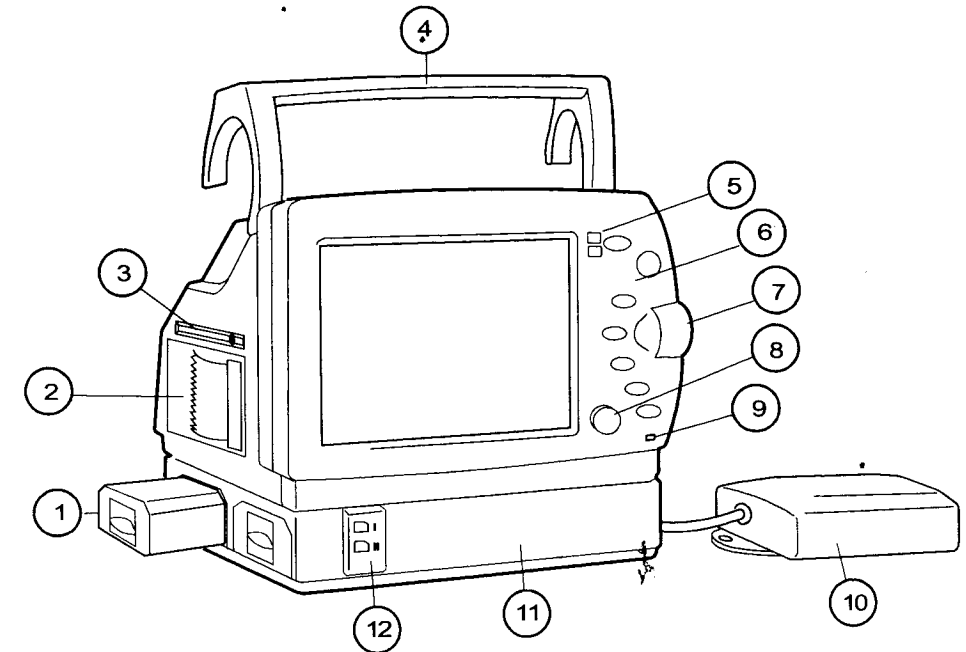

#### 4-1 S/5 Light Monitor

- (1) Battery (2 pieces)
- (2) Recorder (option)
- (3) DataCard slot (option)
- (4) Handle with rail hooks
- (5) Alarm indicators
- (6) Function keys
- (7) ComWheel
- (8) Power On/Standby
- (9) External power indicator
- (10) External power adapter
- (11) Battery Module (option)
- (12) Battery charge status LEDs

## Rear panel

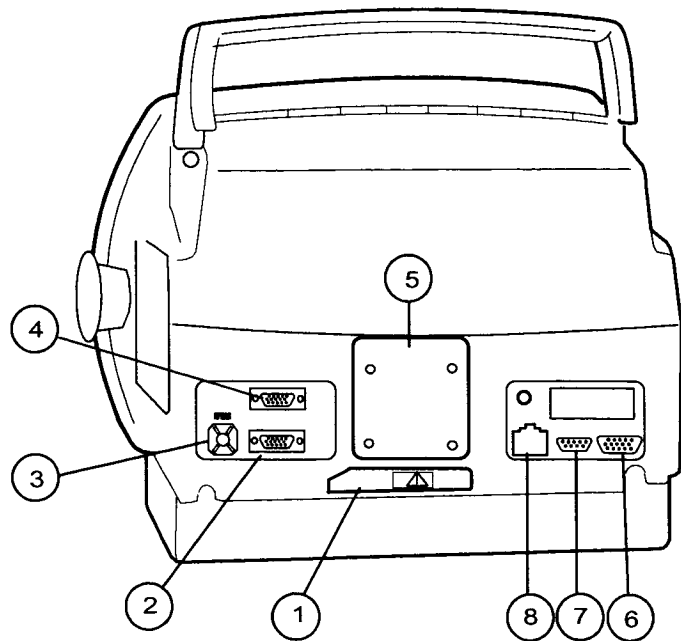

4-2 Rear panel

- (1) Dust filter 
- (2) Feature connector, X3
- (3) Connector for power adapter, X1
- (4) Printer connector (serial), X2
- (5) Mounting attachment
- (6) External VGA connector, X7
- (7) Connector for network location ID plug, X6
- (8) Network connector, X5

## Keys and controls

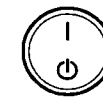

On/Standby.



Returns back to normal monitoring display.



Silences the alarm sound for two minutes.



Calls up the main menu which enables changing the monitor settings.



Opens NIBP mini menu for autocycling or a single non-invasive blood pressure measurement. Cancels any NIBP measurement.



Zeros all invasive pressure lines (except ICP which needs to be zeroed separately, see chapter "Invasive pressure").



Stops the waveform sweep for 60 seconds. Pressing it again unfreezes the sweep.



Starts/stops recording of selected waveforms with the built-in recorder.

## ComWheel

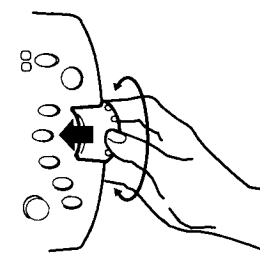

Menu functions are controlled by turning and pressing the ComWheel.

## Display

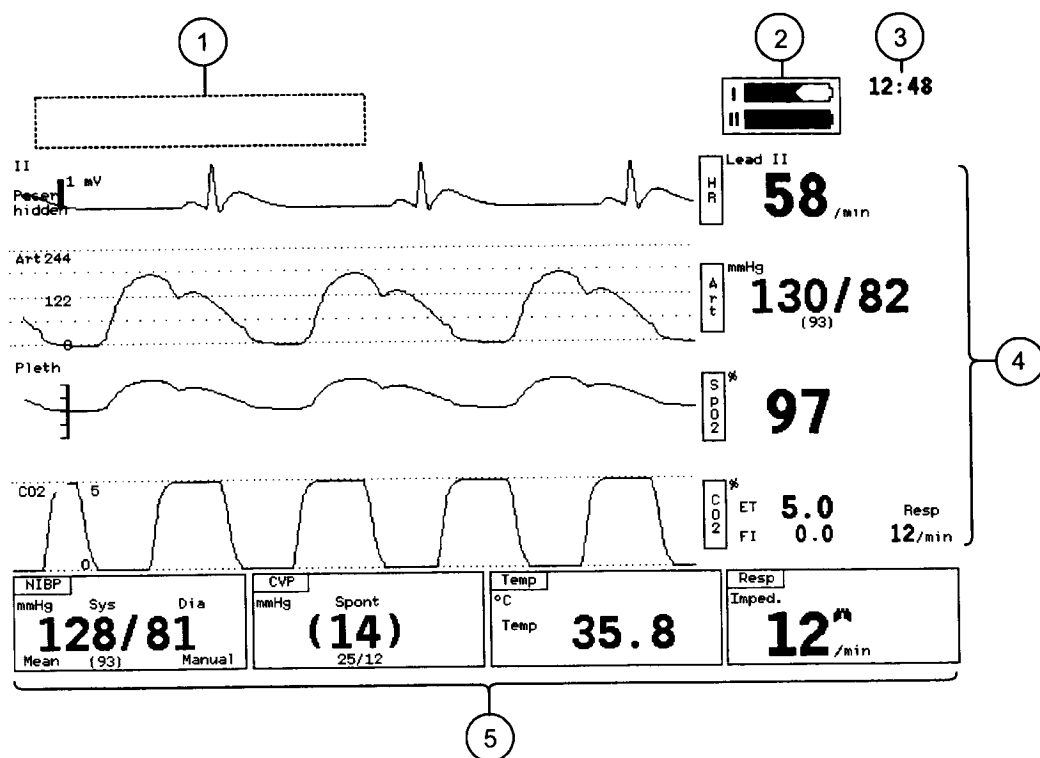

### 4-3 Parts of the display

- (1) Alarm message field (for five messages)
- (2) Battery status field
- (3) Actual time
- (4) Up to four waveform fields with numeric information
- (5) Up to four digit fields

The waveform and digit fields are configurable, see chapter "Monitor setup."

## Measurement connectors

Connectors for measurement sensors are in the right side panel. Connectors are marked with the measurement abbreviations and symbols specifying the type of protection against electrical shock.

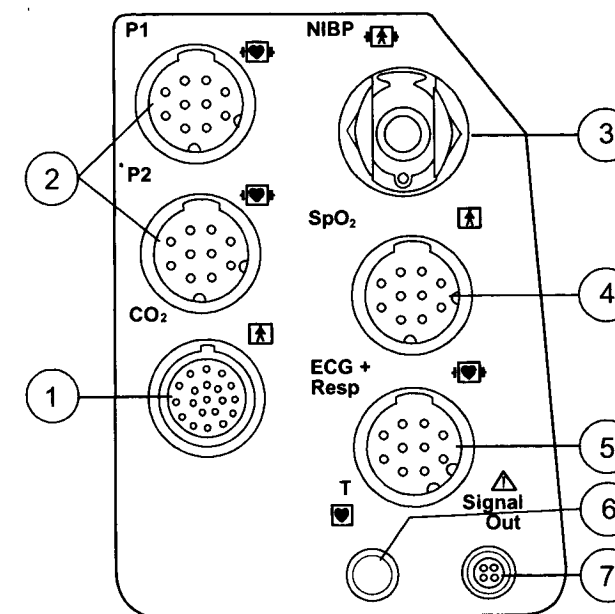

### 4-4 Connector panel

- (1) Mainstream CO<sub>2</sub> connector
- (2) Connectors for invasive pressure lines
- (3) NIBP hose connector
- (4) Pulse oximetry sensor connector
- (5) ECG trunk cable connector, also used for impedance respiration measurement
- (6) Temperature probe connector
- (7) Signal out connector

For your notes:

## 5 Operation

### Getting started

- Turn on the power.  
After 10 seconds a start-up display will appear, the CO<sub>2</sub> measurement needs to warm up about 80 seconds in room temperature. If the monitor has been stored in the temperature below freezing point, it takes approximately one hour to warm up.
- Make patient connections, check the accessories.
- Zero invasive lines.
- Check that desired parameters are displayed in digit and waveform fields. If necessary, make appropriate adjustments.

### During monitoring

- Ensure that ECG electrodes have a good skin contact.
- Change pulse oximetry measuring site frequently.
- Observe the cuffed limb frequently during NIBP measurement.

If the monitor is connected to the network, the patient information and alarms can be followed on the screens of the Datex-Ohmeda Central and the S/5 monitors connected to the system.

### In-between patients

- Print trends: see chapter "Recorder."
- Reset previous case: Press **Menu** and select **Patient Data - Reset ALL**.
- Change single use accessories; clean reusable ones.
- Check the monitor and accessories before use.
- Plug in the power cord to charge batteries.

### At the end of the day

- Turn the monitor to standby.
- Remove the power cord.
- Clean the monitor and reusable accessories. Let dry completely.
- Plug in the power cord to charge batteries.

## Using menus

- Press the **Menu** key.

### Main Menu

- ECG & Resp**
- NIBP & Inv. Press
- SpO2 & Temp
- C02
- Alarms Setup
- Trends
- Record/Print
- Patient Data
- Monitor Setup
- Normal Screen

Show ECG&Resp menu to change ECG&Resp settings.

- Select the item by turning and pressing the ComWheel.

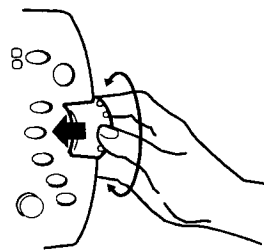

- Change settings by turning and pressing the ComWheel.

### Alarms Setup

- Adjust Limits**
- Auto Limits
- Default Limits
- Cancel Changes
- Alarm Sources
- Alarm Volume
- Audio ON/OFF
- Alarm History
- Remove Menu
- Main Menu

Push wheel to adjust alarm limits manually

#### ALARM LIMITS AND 10 MIN TRENDS:

◀ Exit

HR	NIBP Sys	Art 1 Sys	SpO2	C02 ET	C02 FI	Resp Rate
160	180	180	100	8.0	3.0	60
40	80	80	90	3.0	0.0	4
38.0						
10.0						
Temp						
Temp						

Need help?  
Short instructions appear in every menu.

- Press **Normal Screen**.

26

27

For your notes:

## 6 Batteries

The monitor can be equipped with either the Battery Module (F-LBAT) with two removable batteries, or the Backup Battery (N-LBB) with a built-in battery pack in the monitor basement.

Battery capacity is displayed on the battery status field. The arrow shows the discharging (left) and recharging (right) level of the battery.



The Battery Module works for two hours (one hour / battery) and Backup Battery for 30 minutes with fully charged batteries.

NOTE: Make sure that there is enough battery capacity for a patient transport.

### Charging batteries

- Charge the batteries in +10...40 °C (50...104 °F) only.

### Charging in the monitor

- Keep the monitor connected to power outlet. The batteries are charged when the monitor is either ON or STANDBY.
- If monitor is turned ON, an arrow to the right is displayed on the Battery Status field during charging.
- The green LEDs on the battery module keep flashing until the battery is fully charged.

Charging empty batteries to full capacity for Battery Module takes approximately 3.5 hours/battery, and for Backup Battery 1.5 hours. The protective case may increase the operating temperature, check the charging status when using it.

## Removing batteries from the Battery Module

- Push the release latch down.
- The battery pops out from the frame.

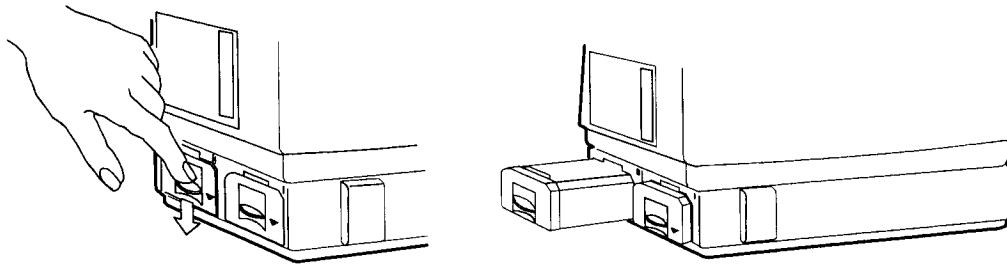

### 6-1 Removing battery packs from the Battery Module

Replace the batteries with new ones if the total operation time is less than one hour. Part number is 896895.

## Battery alarms

If something out of normal routine happens, a corresponding message appears. These battery alarm and note messages are explained in chapter "Maintenance and troubleshooting."

## Battery Maintenance

The batteries will lose the nominal capacity if they are not frequently refreshed properly.

The batteries should be refreshed every three months. Proper refreshing means that the battery is fully discharged by the monitor, and then re-charged fully either with the monitor or with a battery charger. Repeat the refreshing cycle to ensure that the correct capacity information is updated on the memory chip of the battery.

Note that the battery charger (N-LCHGR) does not discharge the batteries.

NOTE: Handle the batteries according to Safety Precautions described in the Technical Reference Manual.

## Storing and disposing of batteries

Keep the batteries in the monitor or external charger. If they are stored for longer periods, store them fully charged in a dry place. Before use, charge them fully.

### CAUTIONS:

Do not put in fire.

Do not short-circuit any terminals.

Do not disassemble or mutilate.

Use only with Battery Module or External Battery Charger.

Do not insert any other than specified batteries into Battery Module or External Charger.

When stored for longer periods or used mostly with mains power; charge and discharge the batteries fully every three months.

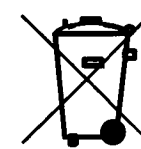

Ni-Cd

This battery contains heavy metal cadmium (Cd), and when disposed, must be separated from other waste according to local regulations.

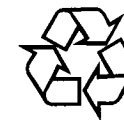

Ni-Cd

Battery packs can be recycled. Discharge before disposing.



For your notes:

## 7 Care and cleaning

### Cleaning

#### WARNING

**ELECTRICAL SHOCK HAZARD:** Before cleaning, disconnect the monitor from electrical outlet. Do not immerse any part of the monitor in liquids or allow liquid to enter the interior.

Do not autoclave any part of the monitor with steam or ethylene oxide. After cleaning, or if liquid has accidentally entered the interior of the monitor, make sure that every part of the monitor is dry before reconnecting it to the power supply.

#### CAUTION

Do not use hypochlorite, acetone-, phenol-, or ammonia-based cleaners.

Cleaning		
Why?	Which items?	How?
To remove dirt and most microbes.	All parts daily. The items to be disinfected or sterilized.	NOTE: Always detach accessories from the monitor and the patient before cleaning. <ul style="list-style-type: none"><li>• Wipe away visible organic material using a moist cloth and mild detergent, e.g. Datex-Ohmeda Cleaning Fluid.</li><li>• Rinse as recommended by the detergent manufacturer.</li><li>• Allow to dry completely.</li></ul>

Disinfecting	
Why?	How?
To kill and remove pathogenic microbes.	<p><b>Which items</b></p> <p>Accessories and supplies in contact with the patient's skin or airways.</p> <p><b>With heat:</b></p> <ul style="list-style-type: none"> <li>Wash in a washing machine (at least 1 min at 85°C/185°F).</li> </ul> <p><b>With chemicals:</b></p> <ol style="list-style-type: none"> <li>Immerse in 2% glutaraldehyde for 10 minutes (pH=6.5). After tuberculosis, HIV or hepatitis patient, the treatment time should be 20 min.</li> <li>Rinse carefully and let dry.</li> </ol> <p>or</p> <ul style="list-style-type: none"> <li>Wipe with alcohol and let dry.</li> </ul>

Sterilization	
Why?	How?
To kill the microbes and bacterial spores.	<p><b>Which items?</b></p> <p>Accessories and supplies penetrating the patient's tissue.</p> <ul style="list-style-type: none"> <li>Steam autoclave at maximum 121°C (250 °F) for 15 min.</li> <li>Use ethylene oxide mixture at 50 to 60°C (120 to 140°F). Follow the sterilizer manufacturer's recommendations for required aeration times.</li> <li>Immerse in 2% glutaraldehyde for three hours, rinse carefully and let dry.</li> </ul>

**Dust filter**

Clean the dust filter at least once a month:

1. Pull out the filter frame on the rear panel. Do not remove any screws!
2. Shake the filter and blow out the dust. If the filter is damaged, replace it with a new one (p/n 886841).

**Monitor casing**

1. Wipe gently using a moist cloth and mild detergent.
2. Let dry completely before reconnecting the power cord.

**Pulse oximetry sensors**

1. Wipe the sensor with mild detergent solution.
2. Allow it to dry completely before use.

The Sat Sensors may be sterilized using ethylene oxide.  
 The Sat Sensors are latex free. Take possible patient allergies into account also when selecting the cleaning agent.

**WARNING**

**PATIENT SAFETY: A damaged sensor, or a sensor soaked in liquid, may cause burns during electro-surgery.**

**ECG cables, temperature probes, NIBP hose**

Wipe the cables with mild detergent solution. When necessary, use disinfectant.  
 Always follow the manufacturer's instructions. Disinfect only the items that tolerate the process.

**NIBP cuff**

Clean only when necessary:

1. Remove the bladder from the cuff.
2. Wash the bladder and the cuff in mild detergent solution. Do NOT use alcohol.

**Invasive pressure cables**

1. Wipe the cables with sterile alcohol-based detergent.
2. After cleaning wipe the surfaces with a cloth dampened with sterile water. Dry with a dry cloth.

**Airway accessories**

**Adapters**

Replace the single patient use adapter after each patient. If the adapter is occluded, it can be rinsed with water and air dried. It may then be replaced into the ventilator circuit of the same patient.

Multi-use adapters can be rinsed with water and steam autoclaved. The adapter is designed to withstand 20 sterilization cycles. Before using, check that the adapter windows are dry and residue-free and that the adapter has not been damaged.

Make sure that all traces of alcohol or detergent are rinsed away or dried before connecting to the patient.

**Mainstream CO<sub>2</sub> sensor****WARNING**

**ELECTRICAL SHOCK HAZARD: Do not immerse the sensor in liquids or autoclave it.**

Wipe the sensor with a slightly damp cotton swab. When necessary, use disinfectant.

**Safety checks for software**

The GE Healthcare software design controls include performance of a risk analysis using methods consistent with ISO 14971 Medical devices — Application of risk management to medical devices.

The S/5 Light Monitor software employs watchdog timers, self-monitoring activities (memory, communication and sensor checks), and power-on self diagnostics (e.g. memory checksums). The software continuously monitors the SpO<sub>2</sub> sensor. If excessive sensor current is detected, the message 'Faulty SpO<sub>2</sub> probe' is displayed both in the SpO<sub>2</sub> number field and in the monitor message field, and the old SpO<sub>2</sub> data disappears from the screen.

**Regular checks****ECG, Impedance respiration**

- Check that the 'Leads off' disappears and the waveforms are displayed when the cable is connected to the patient.

**Pulse oximetry**

- Check that the red light is lit in the sensor. Check that the SpO<sub>2</sub> value is displayed and 'Probe off' disappears when the sensor is connected to the patient.

**Temperature**

- Check that the temperature value is displayed when the probe is connected to the patient.

**InvBP**

- Check that the monitor recognizes cable connections (activates the display) for all the pressure channels used and the pressure values are shown. Make sure that all the transducers are zeroed correctly.

**NIBP**

- Ensure that you are using correct cuff size and have selected correct inflation limits.
- Check that the pressure values are displayed.
- Start the Venous Stasis mode and check that the pump is not restarting during the measurement. If it does, the cuff may be leaking.

**CO<sub>2</sub>**

- Attach the mainstream CO<sub>2</sub> sensor to the monitor and check that no error messages appear (for example, 'CO<sub>2</sub> sensor failure.')

**Functioning of the alarms**

- Set a parameter value outside the alarm limits. For example, connect the SpO<sub>2</sub> sensor and adjust the SpO<sub>2</sub> High limit under the measured SpO<sub>2</sub> values. The alarms go from yellow to red according to sequence given in the "Alarm priority categories" table on page 40. Check that the yellow and red LEDs function as indicated in the table.

For your notes:

**Detailed Operation**

8 Alarms .....	39
9 Monitor Setup .....	51
10 Trends .....	61
11 Patient Data .....	67
12 Recording and Printing .....	69
13 Network and Datacard .....	73
14 ECG .....	77
15 Respiration .....	83
16 Pulse Oximetry .....	87
17 Temperature .....	93
18 Non-Invasive Blood Pressure (NIBP) .....	95
19 Invasive Blood Pressure .....	103
20 Carbon Dioxide (CO <sub>2</sub> ) .....	109

## 8 Alarms

In alarm:

- Messages (max. five messages) appear on the alarm message field at the top of the display in the priority order from left to right.
- Audible alarm is heard.
- External Nurse Call signal is active, and if the monitor is connected to the network, the alarm is passed into it.
- Yellow or red alarm indicator (LED) next to the **Silence Alarms** key is illuminated according to the alarm category.
- The measured value, which activates the alarm, flashes and an explanation may appear on the waveform, the digit field, or the alarm message field.

Alarms are active also when the parameter is not selected on the screen unless the alarm source is not turned off. See default settings in "Alarm tables/alarm sources" later in this chapter.

### WARNING

**PATIENT SAFETY: Always make sure that alarm limits are set and alarms are on when monitoring a patient.**

### Alarm categories

Alarms are classified into two types, red and yellow alarms. The alarm type depends primarily upon the physiological significance and the duration of the alarm; e.g., 'Asystole' advances rapidly to the red category.

The alarm messages are displayed in the order of priority from left to right.

Audio alarms follow either General or ISO pattern. This selection can be made in **Install/Service** menu and is stored in permanent memory. Select the same pattern for all the monitors in a hospital.

**8-1 Alarm priority categories**

Category	Visual	Audio pattern	Meaning
Red alarm	Red LED lit, and the alarm message is displayed with white text on red background. If the alarm is connected to measured values, this number field is flashed.	ISO: 3+2 beeps every 6 seconds. --- --	Life threatening situation.
Yellow alarm	Yellow LED lit, and the alarm message is displayed with white text on yellow background. If the alarm is connected to measured values, this number field is flashed.	Triple beep every 20 seconds. --- ---	Serious problem.
Note	Message is displayed.	Single beep. -	Advisory note or equipment related alarm.

**Smart start alarms**

Alarms are automatically active once the patient connection cables are attached. Some alarms have their own specific requirements before they become active:

- Invasive pressures must be within alarm limits for 20 seconds after zeroing.
- Apnea alarm requires at least three detected breaths.
- When apnea alarm is activated, the high and low alarms of CO<sub>2</sub> and respiration will not be activated.

**Silencing alarms**

**WARNING**

**PATIENT SAFETY: Do not turn off audible alarms without assuming continuous, direct observation of the patient.**

Silencing alarms also disables the external Nurse Call signal.

**Silencing alarms for two minutes**

- Press **Silence Alarms**.

The symbol  with a countdown timer appears on the screen, and the message is cleared from the display. Messages of new alarms also appear during silencing period. After two minutes, all silenced alarms and Nurse Call function will return to normal alarm operation.

**To reactivate alarms:**

- Press the **Silence Alarms** key during the silencing period. The alarm sounds of new alarms and the Nurse Call signal are activated.

**Turning audible alarms on and off**

It is possible to silence only apnea, ECG and apnea alarms, or all the alarms:

- Press **Menu**.
- Select **Alarms Setup**.
- Select **Audio ON/OFF**.
- Select **Silence ECG, Silence Apnea, Silence Apnea + ECG** or **Silence ALL**.

**Alarms Setup**

**Audio ON/OFF**

**Activate Alarms**

- Silence Apnea
- Silence Asystole
- Silence Apnea&Asy
- Silence ALL

Reminder Volume 10

Previous Menu

All audible alarms are activated.

If an active alarm is suppressed, the monitor will give a reminder beep every two minutes. (Reminder beep volume can be adjusted by selecting **Reminder Volume**).

If asystole alarm is silenced, and ECG is used as the heart rate source, the HR high and low limits are also silenced.

**Alarm messages**

All messages are listed in chapter "Maintenance and troubleshooting."

**Alarms setup and adjustments**

You can adjust alarm limits and volume, silence alarms permanently, and view alarm status (a 10-minute trend) in **Alarms Setup** menu.

- Press **Menu**.
- Select **Alarms Setup**.

**Alarms Setup**

**Adjust Limits**

- Auto Limits
- Default Limits
- Cancel Changes
- Alarm Sources
- Alarm Volume
- Audio ON/OFF
- Alarm History
- Remove Menu
- Main Menu

Push wheel to adjust alarm limits manually.

ALARM LIMITS AND 10 MIN TRENDS:

HR	NIBP Sys	Art 1 Sys	SpO2	C02 ET	C02 FI	Resp Rate
160	180	180	100	8.0	3.0	60
40	80	80	90	3.0	6.0	4

38.0

Temp 100.0

Temp



**Adjusting alarm limits**

Alarm limits can be adjusted individually (**Adjust Limits**) or set near to real measured patient values (**Auto Limits**).

**To adjust alarm limits:**

- Select **Adjust Limits**.
- Select the desired high or low alarm limit by turning and pressing the ComWheel.
- Adjust the alarm limit up or down by turning the wheel.
- Press the wheel to confirm the adjusted alarm limit.
- Turn the ComWheel to move the highlight either to the next alarm limit or to the **Exit** box.
- Press the ComWheel.
- Press **Normal Screen** to return to normal monitoring.

**To set auto limits**

Auto limits are calculated from the measured patient values at the time when auto limits are selected. These limits enable close patient control with individual alarms.

- Select **Auto Limits**.
- Press **Normal Screen**.

**Other settings**

- Default Limits** Sets the alarms to the default alarm limits.
- Cancel Changes** Returns all the values to those that were valid when the **Alarms Setup** menu was entered.
- Alarm Sources** NIBP and invasive pressure alarms have alternative sources, (systolic, diastolic, mean pressure, or OFF).
- Alarm Volume** The volume of the audio alarms can be adjusted from 1 (soft) to 10 (loud).
- Audio ON/OFF** All alarms or asystole alone can be turned on and off.
- Alarm History** Displays a list of the last 10 alarms message with respective times. Press the ComWheel to get back to **Alarms Setup** menu.
- Remove Menu** Only the alarm limits and 10 minute trends are displayed.

**Automatic alarm recording**

You can record following alarm situations:

1. Asystole
2. HR high/low and Art low simultaneously (in model with invasive pressure)

When the alarm reaches red state, the recorder will print the ECG + P1 waveforms. Printing appears 12 seconds after the alarm situation has started.

To set alarm recording, press **Menu** and select **Record&Print - Recorder Setup - Start on Alarms YES/NO**.

**Alarm tables**

**Alarm sources**

If alarm source is OFF, no alarms of this parameter occur and the parameter box with the 10 minute trend is not displayed in the **Alarm Setup** menu.

**8-2 Alarm source alternatives and defaults**

Alarm	Source alternatives [Default selection]
P1	[Sys] Dia Mean OFF
P2	Sys Dia Mean [OFF]
Art	[Sys] Dia Mean OFF
CVP	Sys Dia Mean [OFF]
PA	Sys Dia Mean [OFF]
ICP	Sys Dia Mean [OFF]
NIBP	[Sys] Dia Mean OFF

**Default limits**

The monitor is delivered with a certain set of alarm limits, so called factory default limits. These are listed for each parameter in the following tables.

It is possible to save alarm adjustments as defaults, see chapter "Monitor setup", submenu **Install/Service** menu.

Do not change default settings without common consent of all users. If you change the default alarm limit, write the new limits in the following table.

**8-3 Adjustment ranges and default settings of alarm limits**

Parameter	Limit	Limit range min-max	Factory default	User default
HR	High	35-250 bpm	160	
	Low	30-245 bpm	40	
SPO <sub>2</sub>	High	51-100%, OFF	OFF	
	Low	50-100%	90	
NIBP Sys	High	15-265, OFF	180 (120 infant)	
	Low	OFF, 15-265	80(70 infant)	
Mean	High	15-265, OFF	140(90 infant)	
	Low	OFF, 15-265	60(50 infant)	



Parameter	Limit	Limit range min-max	Factory default	User default
Dia	High Low	15-265, OFF OFF, 15-265	100(70 infant) 40(40 infant)	
Inv-P1 Sys	High Low	-40 -300, OFF OFF, -40-300	180 80	
Mean	High Low	-40 -300, OFF OFF, -40-300	140 60	
Dia	High Low	-40 -300, OFF OFF, -40-300	100 40	
Inv-P2 Sys	High Low	-40 -300, OFF OFF, -40-300	20 5	
Mean	High Low	-40 -300, OFF OFF, -40-300	15 0	
Dia	High Low	-40 -300, OFF OFF, -40-300	10 -5	
Art Sys	High Low	-40 -300, OFF OFF, -40-300	180 80	
Mean	High Low	-40 -300, OFF OFF, -40-300	140 60	
Dia	High Low	-40 -300, OFF OFF, -40-300	100 40	
CVP Sys	High Low	-40 -300, OFF OFF, -40-300	20 5	
Mean	High Low	-40 -300, OFF OFF, -40-300	15 0	
Dia	High Low	-40 -300, OFF OFF, -40-300	10 0	
PA Sys	High Low	-40 -300, OFF OFF, -40-300	40 10	
Mean	High Low	40 -300, OFF OFF, -40-300	30 5	
Dia	High Low	-40 -300, OFF OFF, -40-300	20 5	

Parameter	Limit	Limit range min-max	Factory default	User default
ICP Sys	High Low	-40 -300, OFF OFF, -40-300	20 0	
Mean	High Low	-40 -300, OFF OFF, -40-300	15 0	
Dia	High Low	-40 -300, OFF OFF, -40-300	10 0	
EtCO <sub>2</sub>	High Low	0.1 - 13%, OFF OFF, 0 - 12.9%	8%(60 mmHg, 8.1 kPa) 3%(23 mmHg, 3 kPa)	
FiCO <sub>2</sub>	High Low	0 - 3.0%, OFF OFF, 0 - 2.9%	3%(23 mmHg, 3 kPa) OFF	
Resp	High Low	5 - 60, OFF OFF, 4 - 59	60 4	
Temp	High  Low	10 - 45 °C, OFF (50 - 113 °F, OFF) OFF, 10 - 45 °C (OFF, 50 - 113 °F)	38 °C (100 °F)  15 °C (59 °F)	

**Auto alarm limits**

*Auto Limits* are based on the measured patient values according to the following tables.

**8-4 Auto alarm limits**

Alarm	Limit	Auto limit calculation
HR	High Low	HR x 1.25 HR x 0.75
Pulse Oximetry	Low	SpO <sub>2</sub> - 5%
NIBP Sys	High Low	NIBP x 1.25 + 10 NIBP x 0.75 - 10
Mean	High Low	NIBP x 1.25 + 10 NIBP x 0.75 - 10
Dia	High Low	NIBP 1.25 + 10 NIBP x 0.75 - 10

Alarm	Limit	Auto limit calculation
Inv-P1 Sys	High	$P1 \times 1.25 + 10$
	Low	$P1 \times 0.75 - 10$
Mean	High	$P1 \times 1.25 + 10$
	Low	$P1 \times 0.75 - 10$
Dia	High	$P1 \times 1.25 + 10$
	Low	$P1 \times 0.75 - 10$
Inv-P2 Sys	High	$P2 \times 1.25 + 5$
	Low	$P2 \times 0.75 - 5$
Mean	High	$P2 \times 1.25 + 5$
	Low	$P2 \times 0.75 - 5$
Dia	High	$P2 \times 1.25 + 5$
	Low	$P2 \times 0.75 - 5$
Art Sys	High	$P1 \times 1.25 + 10$
	Low	$P1 \times 0.75 - 10$
Mean	High	$P1 \times 1.25 + 10$
	Low	$P1 \times 0.75 - 10$
Dia	High	$P1 \times 1.25 + 10$
	Low	$P1 \times 0.75 - 10$
CVP Sys	High	$CVP \times 1.25 + 5$
	Low	$CVP \times 0.75 - 5$
Mean	High	$CVP \times 1.25 + 5$
	Low	$CVP \times 0.75 - 5$
Dia	High	$CVP \times 1.25 + 5$
	Low	$CVP \times 0.75 - 5$
PA Sys	High	$PA \times 1.25 + 10$
	Low	$PA \times 0.75 - 10$
Mean	High	$PA \times 1.25 + 10$
	Low	$PA \times 0.75 - 10$
Dia	High	$PA \times 1.25 + 10$
	Low	$PA \times 0.75 - 10$
ICP Sys	High	$ICP \times 1.25 + 5$
	Low	$ICP \times 0.75 - 5$
Mean	High	$ICP \times 1.25 + 5$
	Low	$ICP \times 0.75 - 5$

Alarm	Limit	Auto limit calculation
Dia	High	$ICP \times 1.25 + 5$
	Low	$ICP \times 0.75 - 5$
EtCO <sub>2</sub>	High	$EtCO_2 + 1\%$
	Low	$EtCO_2 - 1\%$
FiCO <sub>2</sub>	High	OFF
	Low	OFF
Resp	High	$RR \times 1.25 + 2$
	Low	$RR \times 0.75 - 2$
Temp	High	$Temp + 1^\circ C (1.8^\circ F)$
	Low	$Temp + 1^\circ C (1.8^\circ F)$

For your notes:

## 9 Monitor setup

The **Monitor Setup** menu enables you to select the information displayed on the screen, to set the time and date and to change the default settings via the **Install/ Service** menu.

Getting to **Monitor Setup**:

- Press **Menu**.
- Select **Monitor Setup**.

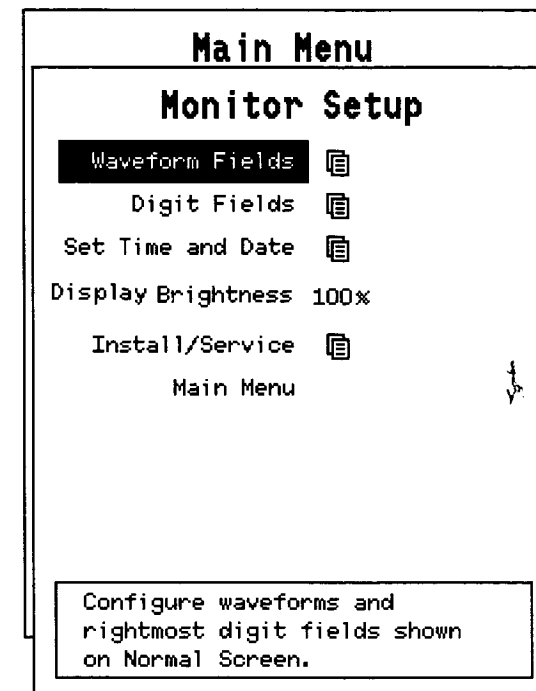

### Screen setup

Select the parameters displayed in the waveform and lower digit fields. A parameter can be displayed in one place only at the time. The monitor turns to the default settings every time it is turned off. If you want to save a certain screen setup as default, see **Install/ Service** adjustments later in this chapter.

### Selecting waveforms

Four waveforms can be displayed. If one field is set to 'OFF', the remaining waveforms are enlarged to fill the area.

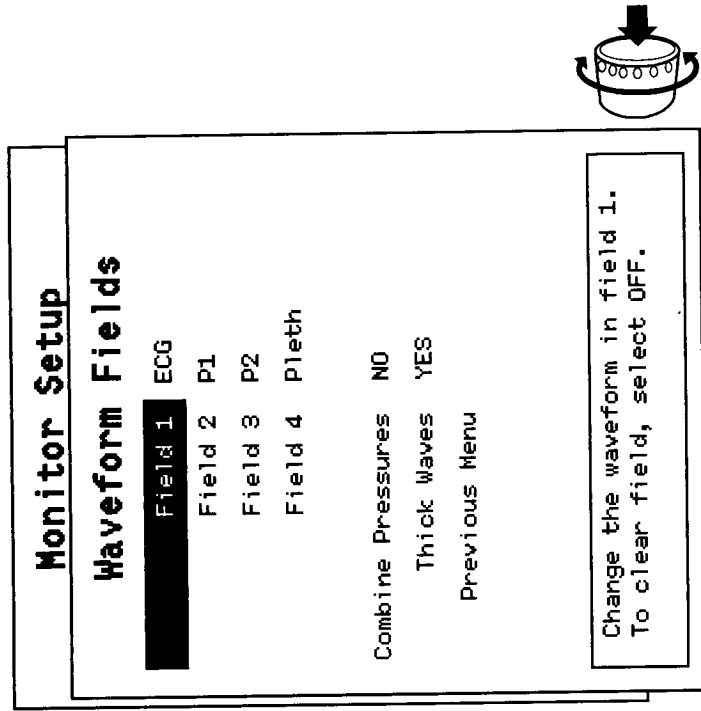

- Select **Waveform Fields**.
- Select the field you want to rearrange.
- Select the parameter from the list.
- Press **Normal Screen**.

Selecting **Combine Pressures YES** displays invasive pressures in the same field (only in models with invasive pressure). Selecting **Thick Waves YES** draws the displayed waveforms with thicker trace.

### Selecting numerical display fields

There are four fields in the lower part of the screen for numeral information, fields are numbered from left to right. If a digit field is turned OFF the digit field to its left is automatically enlarged to fill the space.

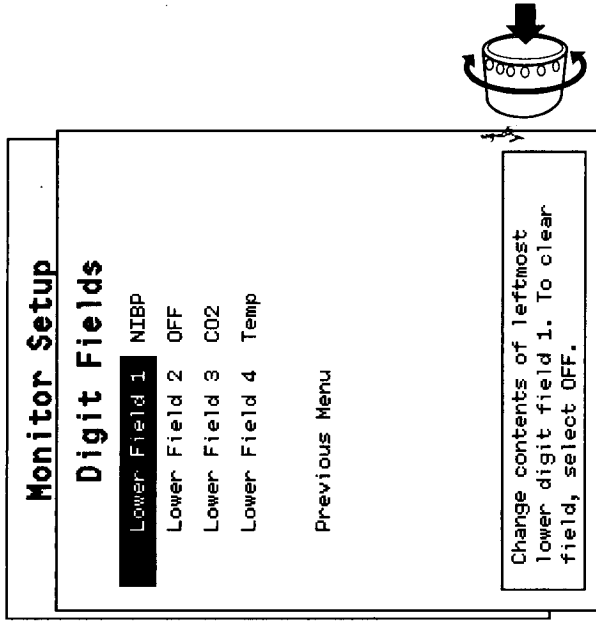

Select **Digit Fields**.

- Select the field you want to rearrange.
- Select the parameter from the displayed list.
- Press **Normal Screen**.

### Setting time & date

- Press **Menu**. Select **Monitor Setup - Set Time and Date**.

The time is shown in the upper right corner of the screen. Turning the monitor off does not affect the clock. You can adjust hours, minutes, seconds, day, month, and year, or select the clock format of either 12 or 24 hours.

#### CAUTION

Do not change the monitor's time settings during patient monitoring. Trend data may be lost.

NOTE: If the monitor is connected to network, the time is set by the network, and cannot be adjusted in the monitor.

## Adjusting the display brightness

1. Select **Display Brightness**.
2. Select from 25 to 100 %.

## Install/Service menu

To enter **Install/Service** menu, a password 16-4-34 must be given. **Service View** Service View is for a qualified technician only. It is entered with a password.

**Alarm Tones** Select **ISO** or **General** pattern, see chapter "Alarms."

### Save As Defaults

Saves permanently your new settings and configurations.

The choices are **Save ALL**, **Screen Setup**, **Trend Setup**, **Alarm Settings**, **Recorder Setup** and **Param. Defaults**. Select **Save** to save settings, **Cancel** to cancel changes, or **Factory** to return to the factory settings.

### Analog outputs

Select the parameter for four analog outputs, as default, they all are off.

Channel	Pin	Selection range
1	#3 in Signal Out connector	ECG or test signals
2	#4 in Signal Out connector	P1 or test signals
3	#5 in feature connector	freely selectable
4	#10 in feature connector	freely selectable

### Previous Menu

Return to **Monitor Setup** menu.

## Default settings

Default settings are always on when the monitor is turned on. They are marked in the following tables with brackets.

If you change the default settings using **Save as Defaults**, please write them down in the empty column. Do not change default settings without common consent of all users.

## 9-1 Monitor setup selections and factory defaults

Monitor settings		
Parameter	Alternatives [Default selection]	User default
<b>Waveform Fields</b>		
Field 1	OFF [ECG] P1 P2 PLETH CO <sub>2</sub> Resp	
Field 2	[OFF] ECG P1 P2 PLETH CO <sub>2</sub> Resp (*P1, **Pleth, ***P1)	
Field 3	OFF ECG P1 P2 [PLETH] CO <sub>2</sub> Resp (**CO <sub>2</sub> )	
Field 4	[OFF] ECG P1 P2 PLETH CO <sub>2</sub> Resp (**CO <sub>2</sub> )	
Combine Pressures	YES [NO]	
Thick Waves	[YES] NO	
<b>Digit Fields</b>		
Lower Field 1	OFF HR P1 P2 [NIBP] SpO <sub>2</sub> CO <sub>2</sub> Resp Temp	
Lower Field 2	[OFF] HR P1 P2 NIBP SpO <sub>2</sub> CO <sub>2</sub> Resp Temp(*P2, ***P2)	
Lower Field 3	OFF HR P1 P2 NIBP SpO <sub>2</sub> CO <sub>2</sub> Resp [Temp]	
Lower Field 4	OFF HR P1 P2 NIBP SpO <sub>2</sub> CO <sub>2</sub> [Resp] Temp (**OFF)	
<b>Set Time and Date</b>		
Clock Format	12 [24]	
<b>Parameter settings</b>		
Parameter	Alternatives [Default selection]	User default
<b>ECG</b>		
ECG Lead	I [II] III	
Size	[1.0] 0.2-5.0	
Beat Sound Volume	[0] 0-10	
Color	Green	
<b>ECG Setup</b>		
Sweep Speed	12.5 [25] 50	
HR Source	[AUTO] ECG Pleth	

Parameter settings		
Parameter	Alternatives [Default selection]	User default
Grid	ON [OFF]	
Pacemaker	Show [Hide] On R	
<b>Pulse Oximetry</b>		
Beat Sound Volume	[0] 0-10	
Pleth Scale	AUTO 50 [20] 10 5 2	
Color	Yellow	
<b>SpO2/Pleth Setup</b>		
Sweep Speed	12.5 [25] 50	
HR Source	[AUTO] ECG Pleth	
SpO2 Response	B-to-B Normal [Slow]	
<b>Temperature</b>		
<b>Temp Setup</b>		
Unit	[°C] °F	
Label	[Temp] Eso Naso Tymp Rect Blad Axil Skin AirW Room Myo Core Surf	
Color	White	
<b>Invasive Pressures</b>		
<b>P1 Setup</b>		
Label	P1 [Art] CVP ICP PA	
Scale	[200] 10-300	
Digit Format	[S/D] Mean	
Sweep Speed	12.5 [25] 50	
HR Source	[AUTO] ECG Pleth	
Color	Red	
<b>P2 Setup</b>		
Label	P2 Art [CVP] ICP PA	
Scale	[20] 10-300	
Digit Format	[S/D] Mean	

Parameter settings		
Parameter	Alternatives [Default selection]	User default
Sweep Speed	12.5 [25] 50	
HR Source	[AUTO] ECG Pleth	
Color	Blue	
<b>NIBP</b>		
Set Cycle Time	1 2.5 3 5 10 [15] 30 60	
Color	Red	
<b>NIBP Setup</b>		
Ready Prompt	[5] 0-10	
Inflation Limits	150 200 [280] mmHg	
<b>CO<sub>2</sub></b>		
Scale	[6] 10 15 (% , kPa) (50 80 100 mmHg)	
Unit	[%] kPa mmHg	
Sweep Speed	[Fast] Slow	
Color	White	
MS or OFF	[MS] OFF	

Recording and Printing		
Parameter	Alternatives [Default selection]	User default
Waveform 1	OFF [ECG] P1 P2 PLETH	
Waveform 2	[OFF] ECG P1 P2 PLETH (*P1, **Pleth, ***P1, )	
Waveform 3	OFF ECG P1 P2 [PLETH] (**CO <sub>2</sub> , ***CO <sub>2</sub> )	
Graphic Trend 1	[HR] P1 P2 NIBP SpO <sub>2</sub> Pleth CO <sub>2</sub> Resp Temp	
Graphic Trend 2	HR P1 P2 NIBP [SpO <sub>2</sub> ] Pleth CO <sub>2</sub> Resp Temp	
<b>Recorder Setup</b>		
Start on Alarms	YES [NO]	
Waveform Delay	[12 s] OFF	

Recording and Printing		
Parameter	Alternatives [Default selection]	User default
Trend Resolution	1 [5] 10 30	
Paper Speed	6.25 12.5 [25]	
Recording Length	[30 s] Cont	

Display Trends		
Parameter	Alternatives [Default selection]	User default
Trend Setup / Trend Page 1		
Field 1	Real-time ECG in all models	
Field 2	OFF ECG [HR] P1 P2 NIBP SpO <sub>2</sub> Pleth CO <sub>2</sub> Resp Temp	
Field 3	OFF ECG HR P1 P2 [NIBP] SpO <sub>2</sub> Pleth CO <sub>2</sub> Resp Temp	
Field 4	OFF ECG HR P1 P2 NIBP [SpO <sub>2</sub> ] Pleth CO <sub>2</sub> Resp Temp	
Field 5	OFF ECG HR P1 P2 NIBP SpO <sub>2</sub> Pleth CO <sub>2</sub> [Resp] Temp (**CO <sub>2</sub> , ***CO <sub>2</sub> )	
Trend Setup / Trend Page 2		
Field 1	Real-time ECG in all models	
Field 2	OFF ECG [HR] P1 P2 NIBP SpO <sub>2</sub> Pleth CO <sub>2</sub> Resp Temp (**SpO <sub>2</sub> )	
Field 3	OFF ECG HR P1 P2 NIBP [SpO <sub>2</sub> ] Pleth CO <sub>2</sub> Resp Temp (*P1, **Pleth, ***P1)	
Field 4	OFF ECG HR P1 P2 NIBP SpO <sub>2</sub> [Pleth] CO <sub>2</sub> Resp Temp (*P2, **CO <sub>2</sub> , ***P2)	
Field 5	OFF ECG HR P1 P2 NIBP SpO <sub>2</sub> Pleth CO <sub>2</sub> Resp [Temp] (**Resp)	
Trend Setup / Trend Page 3		
Field 1	Real-time ECG in all models	
Field 2	[OFF] ECG HR P1 P2 NIBP SpO <sub>2</sub> Pleth CO <sub>2</sub> Resp Temp (*HR, **HR, ***SpO <sub>2</sub> )	

Display Trends		
Parameter	Alternatives [Default selection]	User default
Trend Setup / Trend Page 1		
Field 3	[OFF] ECG HR P1 P2 NIBP SpO <sub>2</sub> Pleth CO <sub>2</sub> Resp Temp (*SpO <sub>2</sub> , **SpO <sub>2</sub> , ***Pleth)	
Field 4	[OFF] ECG HR P1 P2 NIBP SpO <sub>2</sub> Pleth CO <sub>2</sub> Resp Temp (*Pleth, **Temp, ***CO <sub>2</sub> )	
Field 5	[OFF] ECG HR P1 P2 NIBP SpO <sub>2</sub> Pleth CO <sub>2</sub> Resp Temp (*Temp, **Resp)	

\*) default in models with invasive pressure,  
 \*\*) default in models with CO<sub>2</sub>,  
 \*\*\*) default in models with invasive pressure and CO<sub>2</sub>

For your notes:

## 10 Trends

The monitor accumulates and displays trend data for user selected periods between 2 and 24 hours.

There are two types of trend screens: graphic trend displays measured data in bars or dots, and numerical trends give the information in tabular form.

In addition a 10-minute trend is displayed in the **Alarm Setup** menu for every parameter with alarm limits.

During trend display, the monitor is active and the numerical information is continuously updated and displayed. Trend data is stored in memory for 15 minutes after the monitor is turned off.



### Viewing graphic trends

- Press **Menu**.
- Select **Trends**.
- Select **Graph 2 h, 4 h, 12 h** or **24 h**.

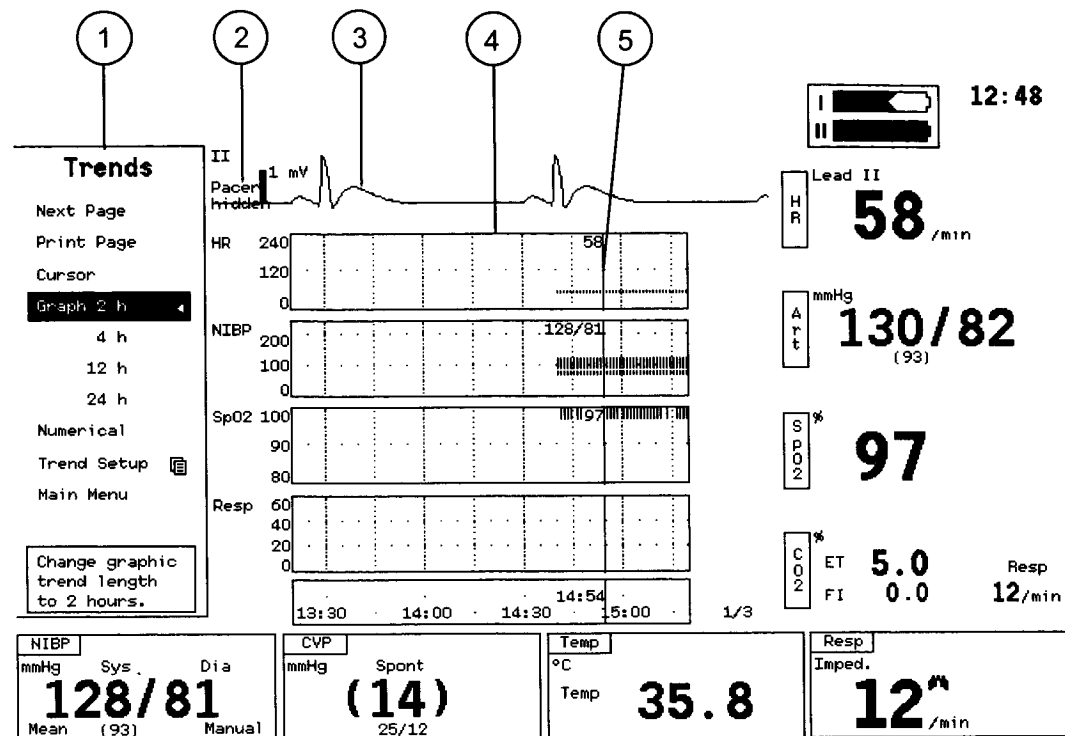

10-1 Graphic trend

- (1) List of selections
- (2) Labels
- (3) Real time ECG above the trend information
- (4) Parameter trend fields
- (5) Movable trend cursor

### Graphic trend pages

There are three pages of graphic trends. Pages are turned by selecting **Next Graph**. The page that is viewed last is stored in memory. It appears first when trends are viewed again.

10-1 The parameters trended in three pages

1st Page			
Basic model	Model with invasive pressure	Model with CO <sub>2</sub>	Model with invasive CO <sub>2</sub> pressure
ECG	ECG	ECG	ECG
HR	HR	HR	HR
NIBP	NIBP	NIBP	NIBP
SPO <sub>2</sub>	SPO <sub>2</sub>	SPO <sub>2</sub>	SPO <sub>2</sub>
Resp	Resp	CO <sub>2</sub>	CO <sub>2</sub>

2nd Page			
Basic model	Model with invasive pressure	Model with CO <sub>2</sub>	Model with invasive CO <sub>2</sub> pressure
ECG	ECG	ECG	ECG
HR	HR	SPO <sub>2</sub>	HR
SPO <sub>2</sub>	P1	Pleth*	P1
Pleth*	P2	CO <sub>2</sub>	P2
Temp	Temp	Resp	Temp

3rd Page			
Basic model	Model with invasive pressure	Model with CO <sub>2</sub>	Model with invasive CO <sub>2</sub> pressure
ECG	ECG	ECG	ECG
Off	HR	HR	SPO <sub>2</sub>
Off	SPO <sub>2</sub>	SPO <sub>2</sub>	Pleth
Off	Pleth*	Temp	CO <sub>2</sub>
Off	Temp	Off	Resp

Parameters displayed on each page can be selected in **Trend Setup**.

**Resolution**

Resolution of trend display depends on the trend length selected.

**10-2 Trend lengths and resolutions**

Trend length (hours)	Resolution (minutes)
2	1
4	2
12	6
24	12

**Viewing numerical trend**

You may view trend data also in numerical format. The trend information is updated every five minutes and always after NIBP measurement. The latest information is displayed at the bottom of the page.

- Select **Numerical**.

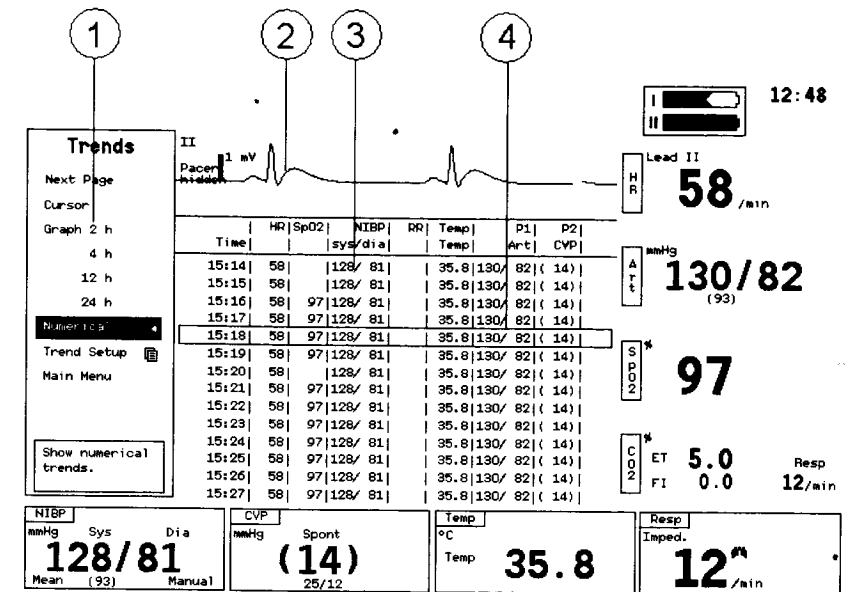

**10-2 Numerical trend page**

- (1) List of selections
- (2) Real time ECG above the trend information
- (3) Numeric trend information
- (4) Movable cursor

Parameters displayed are:

HR; SpO<sub>2</sub>; NIBP sys/dia; P1/Art sys/dia; P1/CVP mean; CO<sub>2</sub> Et/Fi; RR

## Changing trend setup

Trend Setup	
Page 1	
Field 1	ECG/r
Field 2	HR
Field 3	NIBP
Field 4	SpO2
Field 5	Resp
Previous Menu	
Change contents of field 1. To clear field, select OFF.	

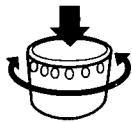

- Select **Trend Setup** in **Trends** menu.
  - Select the graphic trend page you want to change.
  - Select the parameter for each field, or select **OFF**.
- If you want to make your trend setup permanent you can store it, see chapter "Monitor setup/Default settings."

## Erasing trend data

- Press **Menu**.
- Go to **Patient Data**.
- Select **Reset Trends**.
- Select **YES** to confirm resetting trends.

## 11 Patient data

**Patient Data** menu is used for identifying the patient case and erasing trends and settings.

To stop a monitoring case, reset trends between patients. Alternatively you can reset all data and settings. If the trends are just being printed, they cannot be erased. A message 'Resetting not possible during printing. Please wait until printing is completed.' appears.

The **Patient Data** menu will open automatically when the monitor is started less than 15 minutes after previous case, and the trends have not been erased. This is to confirm that the collected data is connected to the right patient.

- Press **Menu**.
- Select **Patient Data**.

Main Menu	
Patient Data	
Last Name	
First Name	
Patient ID	
Reset Trends	
Reset ALL	
Main Menu	
Give patient's last name.	

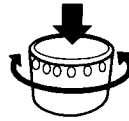

**Last Name**

Give patients last name, max. 14 characters, with ComWheel.

**First Name**

Give patients first name, max. 14 characters, with ComWheel.

**Patient ID**

Give patients ID, max. 14 characters, with ComWheel. This starts the case, the message 'Case started' is displayed.

**Reset Trends** Erase trend memory between patients. Select **YES** to confirm the erasing, the message 'Case ended' is displayed.

**Reset ALL** Return all the settings to their defaults and erase trend and alarm memory. Select **YES** to confirm the erasing, the message 'Case ended' is displayed.

**Main Menu** Return to **Main Menu**.

The **Last Name**, **First Name** and **Patient ID** can be entered also from the Datex-Ohmeda Central via network. The name is displayed as long as there are less than five alarm messages displayed simultaneously.

## 12 Recording and printing

The optional built-in recorder provides single, dual and triple real time waveform recording, and single and dual recordings of numerical information. In addition it can record up to 24 hours of graphic and numerical trend data.

**NOTE:** Printings on thermal paper may be destroyed when exposed to light, heat, alcohol etc. Take a photocopy for archives. Graphical trend data can also be printed on the laser printer either from the local port, or, if the monitor is connected to network, using a central printer.

### Recording

- Press **Recorder Start/Stop** to start and stop recording.
- NOTE:** Scaling of recorded waveforms follows the displayed parameter scaling, when applicable.

### Selecting the waveforms to be recorded

- Select up to three waveforms you wish to record in **Menu - Record/Print - Wave Setup** menu.

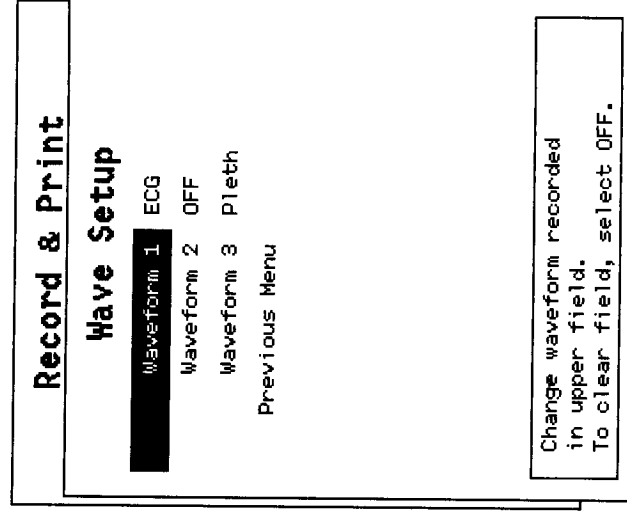

**Waveform x** Select the recorded waveforms.

## Recording trends

- Press **Menu** and select **Record/Print**.
  - Start recording by selecting **Record Graph. Trend**, or **Record Num. Trend**, or **Record Tab. Trend**.
  - Stop printing by selecting **Stop Graph./Num./Tab. Trend**.
- To select the graphical trend you want to record, go to **Menu - Record/Print - Graph - Trend Setup**.

## Other recorder settings

To make the following selections, go to **Menu - Record/Print - Recorder Setup**:

### Start on Alarms

Select if an alarm activates the recorder or not (**YES / NO**).  
Recording time is 30 seconds: 12 seconds recording from the recorder memory, 18 seconds real time recording. Alarm source annotated.

### Waveform Delay

Select the amount of waveform data (in seconds) that will be stored in the recorder memory and printed before real-time waveform. The choices are: **OFF** or **12 seconds**.

**Paper Speed** Select the paper speed **6.25**, **12.5**, or **25** mm/seconds.

### Recording Length

Select the printing time, either 30 seconds or continuous.

### Previous Menu

Return to **Record&Print** menu.

## Recorder paper replacement

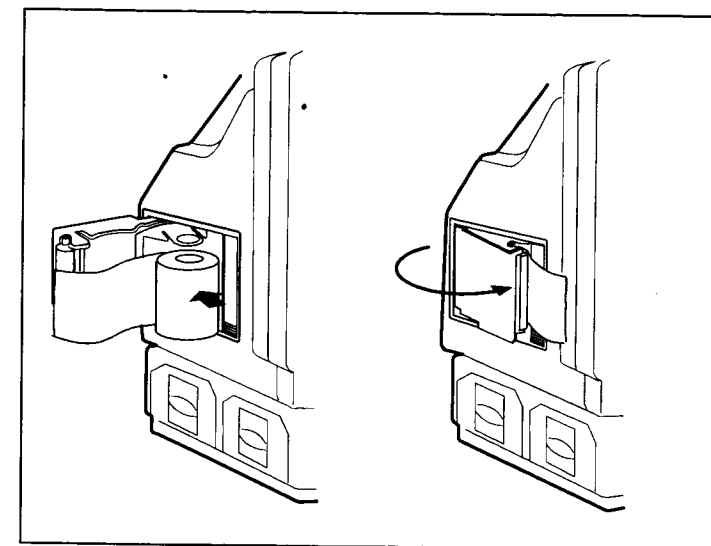

12-1 Placing paper roll

## Printing

Graphical trend pages P1, P2, and P3 can be printed either separately or all together. Print with a local laser printer, or if the monitor is connected to the network, with a central laser printer.

To print:

- Press **Menu**.
  - Select **Record/Print**.
  - Select **Print Graphical**.
  - Select **Print Graphs**.
- or
- Press **Menu**.
  - Select **Trends**.
  - Select **Print Page**.

### Selecting the printer

- Press **Menu**.
- Select **Record/Print**.
- Select **Print Graphical**.

- Select **Printer Location**.
- Select **Local** for local printing or an appropriate network alternative. Network printers are named in your Datex-Ohmeda Central.

### Selecting the paper size

- Press **Menu**.
- Select **Record/Print**.
- Select **Print Graphical**.
- Select **Printer Paper Size** and the right one of **A4** or **Letter** size.

### Printer installation

A laser printer can be connected to the monitor's serial connector and used as the local printer. The printer must be able to use PCL5, and a special converter cable (p/n 894193) is required when using the parallel connection. The printers with serial connection can be connected directly to the monitor with a standard cable. Purchase the printer locally. The printer memory should be at least 2 MB.

### WARNINGS

**ELECTRIC SHOCK HAZARD: The printer must be supplied from an appropriate extra separating transformer.**

**ELECTRIC SHOCK HAZARD: Before starting to use the system, ensure that the entire combination complies with the international standard IEC 60601-1-1 and with the requirements of the local authorities.**

### Printer setup

For instructions refer to the printer's documentation. Make sure that the printer settings are set to serial interface.

## 13 Network and DataCard

The monitor can be equipped with following options to enhance data continuum capabilities in the Datex-Ohmeda S/5 information system:

- N-LINET                      Network
- N-LDATA                    DataCard
- N-LDNET                    DataCard and network.

### Networking

If the monitor is connected to the network, the symbol is displayed:



#### When the monitor is connected to network

- Time and date are set by the network and cannot be adjusted in the monitor.
- The patients name can be entered in the **Patient Data** menu to be displayed on the Datex-Ohmeda Central's and the monitor's screen and printed on the laser printouts.
- Measured and entered patient data can be viewed on the Datex-Ohmeda Central.
- Measured patient data and alarms can be viewed on other Datex-Ohmeda S/5 monitoring systems, but not vice versa.

#### Patient view and multi view on the Datex-Ohmeda Central screen

The Patient View on the Datex-Ohmeda Central screen looks like monitor's own screen.

In the Multi View, the measured values from each of the monitor shown on the screen are:

<b>8-Patient mode</b>	<b>16-Patient mode</b>
ECG waveform	ECG waveform
HR, P1, SpO <sub>2</sub> , RR or EtCO <sub>2</sub> numbers	HR numbers
Alarm field	Alarm field

### Monitor-to-Monitor communication

When the monitor is viewed on another S/5 monitor, the following parameters are displayed:

Waveforms	EGC, Pleth, Art, CO <sub>2</sub>
Numbers	HR, SpO <sub>2</sub> , Art, CO <sub>2</sub>
1-hour numerical trend	HR, SpO <sub>2</sub> , NIBP, P1, P2, CO <sub>2</sub>

You cannot view other monitors on the S/5 Light Monitor.

### DataCard

The DataCard is a rewritable flash memory card. With the DataCard, the patient trend data collected with the S/5 Light Monitor can be transferred to other S/5 monitors with record keeping or intensive care softwares, as well as to S/5 monitors with ARK software and S/5 monitors.

Data from any card cannot be loaded to the S/5 Light Monitor, nor loaded from the network to the S/5 Light Monitor or vice versa.

### Inserting and removing the card

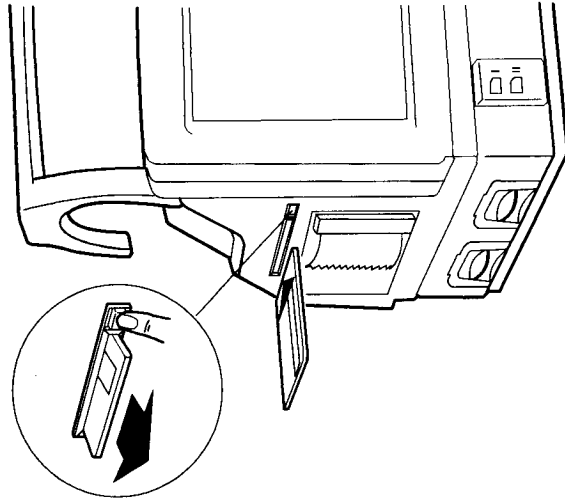

- Push the card into the slot on the left side panel of the monitor.



When the DataCard is inserted, this symbol is displayed. If the symbol is blinking, the card is not inserted properly.

If any other card or a faulty card is inserted, a message 'Faulty DataCard - change card' is displayed.

To remove the card:

- Push the lever on the side of the slot.

### Collecting data

When the card is inserted, the continuous patient trend data is automatically stored on it. When the card is filled, the oldest data is erased, but only if it is older than two days. You can retrieve information of approximately the last 24 hours. The memory capacity depends on the complexity of the saved data.

For your notes:

## 14 ECG



ECG monitoring is used to: measure the heart rate, detect arrhythmias, monitor pacemaker function, and myocardial ischaemia.

ECG reflects the electrical activity generated by the heart muscle.

You can use 5- and 3-lead sets and trunk cables, but only leads I, II, or III can be measured.

### Monitoring ECG

1.	Connect the patient cable to the blue ECG connector on the monitor's side panel.
	Place the electrodes on the patient. Connect the leadwires to the electrodes. NOTE: Always attach all the electrodes to the patient, also when using a 5-lead cable.
3.	

### Applying electrodes

#### WARNING

#### PATIENT SAFETY:

Ensure proper contact of the electrosurgery return electrode to avoid possible burns on the patient via ECG electrodes and probes. Make sure that no part of the patient connections touches any electrically conductive material, including earth.

### Patient preparation

- Ensure good skin contact with the electrodes. Remove excessive body hair, skin oil etc.



- Check, that the pre-gelled electrodes are moist and have not dried out during storage.

### Placing electrodes

Avoid bones close to the skin, obvious layers of fat and major muscles.

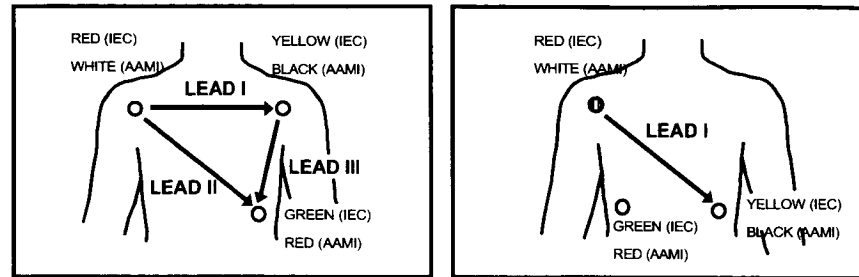

14-1 Lead selections in typical electrode positioning

Left: Standard 3-Lead Positioning

Middle: Modified CB<sub>5</sub> 3-Lead Positioning

Right: Standard 5-Lead Positioning, place the fifth electrode in one of the six places indicated.

### Electrode coding

14-1 IEC and AAMI codes for ECG electrodes

3-LEAD IEC STANDARD	5-LEAD IEC STANDARD
L = yellow (left arm)	R = red (right arm)
F = green (foot)	N = black (neutral)
R = red (right arm)	L = yellow (left arm)
	F = green (foot)
	C = white (chest)
3-LEAD AAMI STANDARD	5-LEAD AAMI STANDARD
LA = black	RA = white
LL = red	RL = green
RA = white	LA = black
	LL = red
	V = brown

### Selecting trunk cable

Use a 5-lead set with a 5-lead trunk cable, and accordingly a 3-lead set with 3-lead trunk cable. (If you have a 3-lead set connected to a 5-lead trunk cable, you must set in the **ECG Setup** menu the selection **5 Lead Cable to 3select**).

If 5-lead trunk cable is used with 3-lead set and 3select is not chosen from the ECG&resp menu, the audible alarms and heart rate calculation are not activated.

### What should happen when electrodes are applied?

- ECG display appears.
- A beep is heard when a QRS complex is detected.

### Selecting ECG lead

- Press the **Menu** key and select **ECG & Resp**.
- Select **ECG Lead**.
- Select one of **I, II, or III**.

NOTE: Only 3 leads are measured, though a 5-lead set and cable are used.

NOTE: To minimize the interference from the electrosurgery unit (ESU), place the electrodes and select the lead so that the current from the surgical burning area to the return electrode does not go through the measured ECG lead.

### ECG display

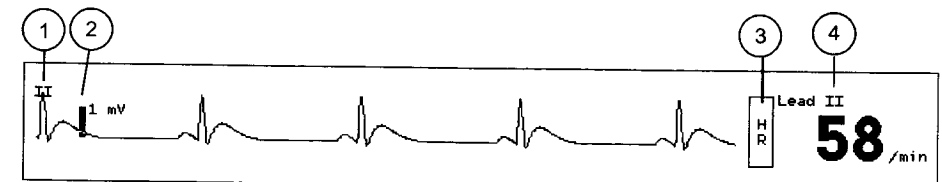

14-2 Display of ECG and HR

- (1) Selected lead label
- (2) 1 mV reference bar
- (3) Heart rate (HR) label
- (4) Heart rate calculation source and message field for HR messages

### Cascaded ECG

If two fields are configured (See "Monitor setup/Waveform fields") for ECG display the waveform continues from one field to another. Thus more QRS complexes are displayed at the same time.

### ECG adjustments

- Press the **Menu** key.
- Select **ECG & Resp.**

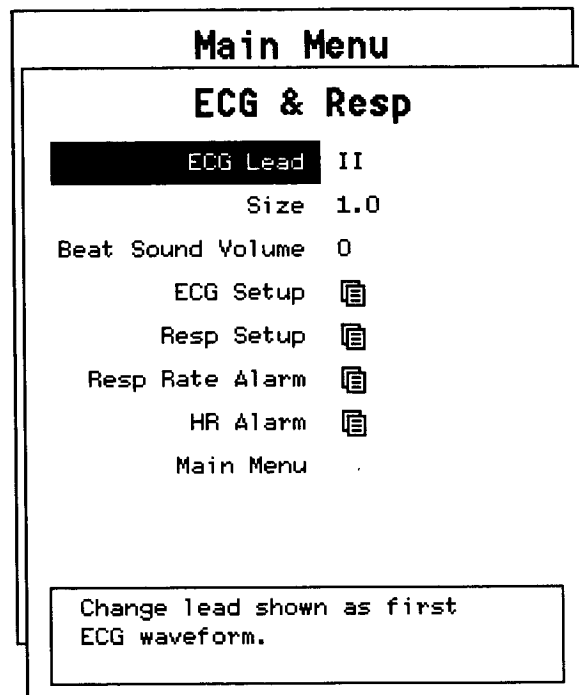

- ECG Lead** Select the displayed lead: *I, II, or III.*
- Size** Adjust from 0.2 to 5 in steps of 0.1. The bar on the left side of the ECG display is 1 mV.
- Beat Sound Volume** A (QRS complex, or a plethysmographic or pressure pulse) produces a beep, and its volume is adjustable from 0 to 10 in steps of 1. Adjusting also changes the beat sound volume of SpO<sub>2</sub>.  
(When SpO<sub>2</sub> is monitored, the tone of the pulse beep rises with increasing oxygen saturation and falls as saturation decreases.)
- ECG Setup** Opens a submenu for ECG settings, see below.

- HR Alarm** Opens a submenu for adjusting heart rate alarm, see chapter "Alarms."
- Resp Setup** Opens a submenu for Respiration settings, see chapter "Respiration."
- Resp Rate Alarm** Opens a submenu for adjusting respiration rate alarm, see chapter "Alarms."

### ECG setup

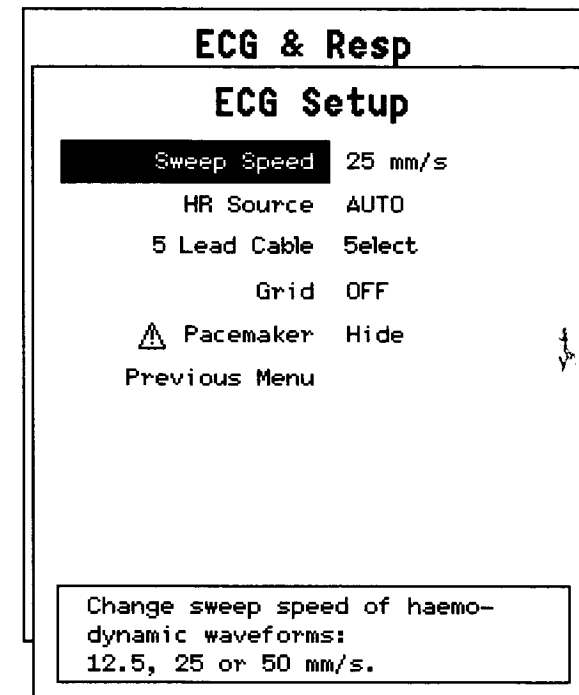

- Sweep Speed** Set the speed of the waveform sweep. Speeds are: **12.5, 25,** and **50 mm/s** on a 9" screen.  
The 12.5 mm/sec speed is suggested for monitoring patients with a slow HR to show more QRS complexes per sweep.  
The 50 mm/sec speed is recommended when monitoring patients with a high HR or when using cascaded ECG.  
NOTE: The sweep speed is same for ECG, plethysmographic, and invasive pressure waveforms.
- HR Source** Select the heart rate source. If ECG signal is too noisy for reliable heart rate calculation, heart rate can be calculated from pressure

(*Art*) or pulse oximetry (*Pleth*). The heart rate source appears above the numerical display of the heart rate.

The **AUTO** selects the first available of ECG, Art, and Pleth.

**5 Lead Cable** If you use a 5-lead trunk cable with a 3-lead set, select **3select** on, otherwise the 'Leads Off' message will be displayed.

**Grid** Select **ON** to display ECG waveform with 0.5 mV grid lines.

**Pacemaker** Selects how to display the pacing pulse of a cardiac pacemaker, **Show**, **Hide** or **ON R**.

**Hide:** The pacing pulse is filtered from the waveform.

**Show:** As above, but the pulse is marked with a constant height marker.

**ON R:** Pacing pulses are not filtered from the waveform. This improves ECG monitoring with A-V pacemaker patients, as the QRS complexes are counted even if the pacing pulse hits the complex. On the other hand, during asystole the monitor may count pacing pulses as heart rate.

## Setting heart rate alarm

Heart rate alarms can be adjusted in the **Alarms Setup** menu or accessed through the **ECG & Resp.** menu. See more detailed instructions in the "Alarms" chapter.

Alarm messages are explained in chapter "Maintenance and troubleshooting; Alarm and information messages."

## Pacemaker patients

The monitor detects and rejects pacemaker pulses, see selection **Pacemaker** in the **ECG Setup** menu. Sometimes this may lead to unnecessary asystole alarms. The pacemaker may well change the shape of QRS so much that QRS detection may be affected.

### WARNING

**PATIENT SAFETY: Monitor may count pacemaker pulses as heart rate during cardiac arrest, some arrhythmias, or with certain types of pacemakers, particularly in ON R mode. Do not rely entirely upon alarms. Keep pacemaker patients under close surveillance.**

## 15 Respiration



Respiration measurement uses ECG electrodes to measure the impedance changes caused by breathing. The measurement is intended for patients three years old and up.

### WARNING

**PACEMAKER PATIENTS: The impedance respiration measurement may cause rate changes in Minute Ventilation Rate Responsive Pacemakers. Set the pacemaker rate responsive mode off or turn off the impedance respiration measurement on the monitor.**

## Monitoring respiration

Respiration measurement is activated when a digit or waveform field is selected for it:

- Press the **Menu** key.
- Select **Monitor Setup**.
- Select **Waveform Fields** or **Digit Fields**.
- Select **Resp.** to be displayed on an appropriate field.

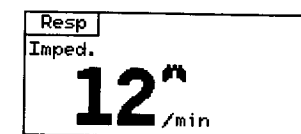

15-1 Respiration display

## Patient connections

Respiration uses the same electrodes as ECG, refer to the "ECG" section of this manual.

## Respiration setup

- Press the **Menu** key.
- Select **ECG & Resp.**
- Select **Resp Setup**.

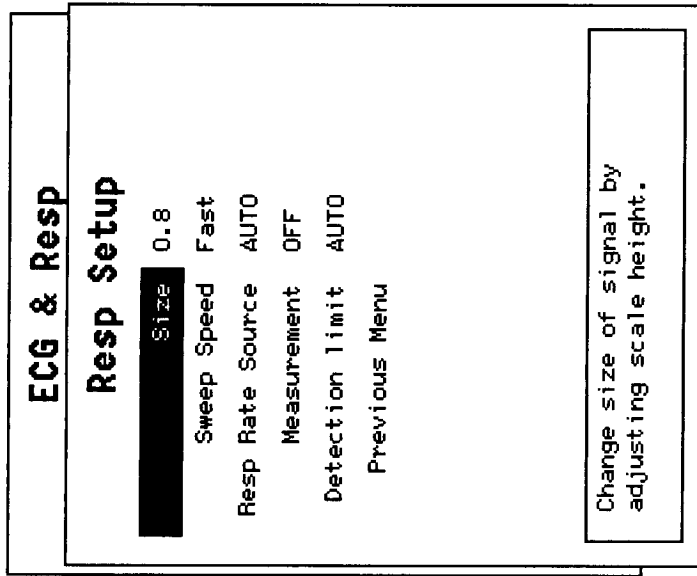

- Size** Adjust the scale height 1...50 mm/Ohm. The bar on the left displays always 1 Ohm.
- Sweep Speed** Set the speed of the waveform sweep. Speeds are: **Fast** 6.25 and **Slow** 0.625 mm/s on a 9" screen.
- Resp. Rate Source** Select the respiration rate source of **AUTO**, **CO<sub>2</sub>** and **Imped**. The **AUTO** sets the CO<sub>2</sub> first, and if it is not available, impedance respiration is used. Default selection is **AUTO**.
- Measurement** Select **ON** to measure impedance respiration and **OFF** to set the measurement off. Default selection is **ON**.
- Detection Limit** Adjusts measurement sensitivity. Selections are **AUTO**, **20%**, **40%**, **60%**, or **100%**. The percentage is the ratio to the 1 Ohm reference bar which is 100%.

**Limitations of measuring**

**Movement artifacts**

Changing the patient position, moving the head, moving the arms or shaking will result in movement artifacts. Also the heart may

cause noticeable movement, and sometimes this may interfere with the respiration measurement.

**Electrical interference**

Electrical devices that emit electromagnetic disturbance will result in artifacts or disable the respiration measurement completely. Such devices are electrosurgery units and infrared heaters, among others.

**Intermittent mechanical ventilation**

During spontaneous breathing the ventilator may at times support the patient's ventilation with an extra inspiration. If these ventilator inspirations are substantially larger than the spontaneous breaths, the respiration calculation may mistakenly count only the ventilator produced inspirations and expirations. You can correct this by manually adjusting the detection limits.

1. Press the **Menu** key.
2. Select **ECG & Resp**.
3. Select **Resp Setup**.
4. Select **Detection limit**.

**Measuring principle**

ECG electrodes are used to measure impedance change across the thorax. Impedance change is caused by movements and changing air volume in the lungs.

Lead selection using 3-lead cables	Signal fed between electrodes	Signal measured
I	L and R	F*
II	F* and R	L
III	F* and L	R
Using 5-lead cables	L and F	N

\*) may be neutral (N) in some older 3-lead sets.

For your notes:

## 16 Pulse oximetry





Pulse oximetry is used for monitoring oxygen saturation (SpO<sub>2</sub>), pulse rate, and plethysmographic waveform.

The plethysmographic pulse waveform reflects the changes in blood pulsation at the measuring site. The amplitude of the waveform reflects the strength of perfusion.

Pulse oximetry is measured with a sensor from finger, toe, ear, or with little children, from palm or feet.

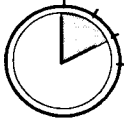
### Monitoring pulse oximetry

1.	Attach the sensor to the gray connector on the monitor's side panel.
	Attach the sensor to the patient. The SpO <sub>2</sub> and pulse rate values, and the plethysmographic pulsewave appear on the screen.
	Change the sensor site frequently.
	Remove the sensor from the patient and clean it.

## Selecting sensor

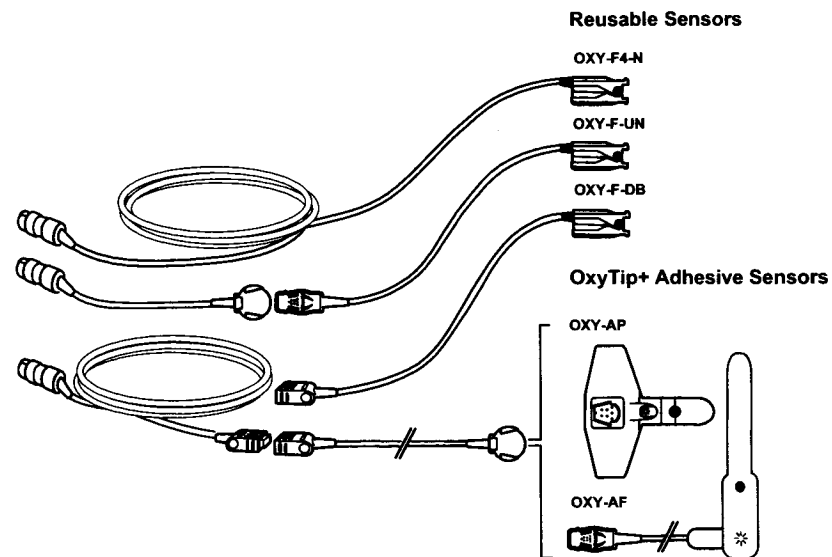

16-1 Sat Sensors for different applications

## Applying sensors

- Use dry and clean sensors only.
- Confirm that red light lights up in the sensor when it is connected to the monitor.
- Clean the application site. Remove nail polish, artificial fingernail, earrings etc. Clip long finger nails.
- Attach the sensor cable to the wrist or bed clothes to prevent cable and sensor from moving.

### WARNING

#### PATIENT SAFETY: Change measuring site frequently.

- Change sensor site and check skin and circulatory status every 2-4 hours with adults, and every hour with little children.

#### What should happen when sensor is applied?

- The message 'Pulse Search' appears.
- When 'Pulse Search' is completed, the pulse rate and SpO<sub>2</sub> value will appear.
- The plethysmographic waveform will appear. The waveform scale is established according to the measured amplitude.

- Pulse beep is heard. The tone of the pulse beep will rise with increasing oxygen saturation and fall as saturation decreases.

## Pulse oximetry display

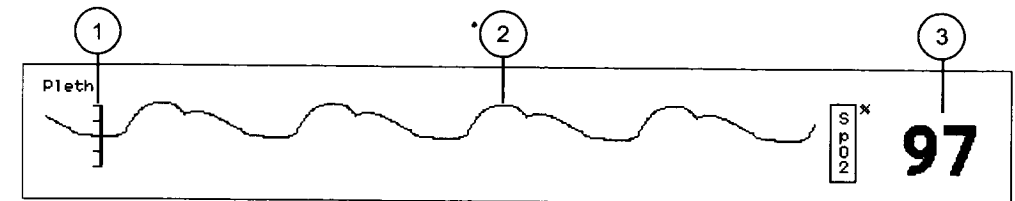

16-2 Plethysmographic waveform with oxygen saturation number

- (1) Bar reflecting the signal amplitude
- (2) Plethysmographic waveform
- (3) Oxygen saturation (SpO<sub>2</sub>)

## Measuring limitations

### Plethysmograph

The waveform is a good indicator of measurement validity. If the wave is noisy, amplitude is low, or the normal waveform cannot be seen, attach the sensor again.

### Dyshemoglobins

The pulse oximeter cannot distinguish between oxyhemoglobin and dyshemoglobins. Thus, the SpO<sub>2</sub> values may be erroneously high in smokers or in patients who have burns or carbon monoxide (CO) intoxication.

### Electrosurgery

Under some circumstances electrosurgery may cause noise on the display. Therefore, be careful in interpreting the results, especially the plethysmographic pulse waveform, during electrosurgery.

### External interference

Ambient light, intravascular dyes and vasoconstrictive drugs may affect the accuracy of the measurement. Improper sensor attachment (measuring site too thick or thin, sensor ends not aligned), or patient movement may also interfere with the measurement.

## Adjustments

- Press the **Menu** key.
- Select **SpO2 & Temp**.
- Select and adjust by turning and pressing the ComWheel.

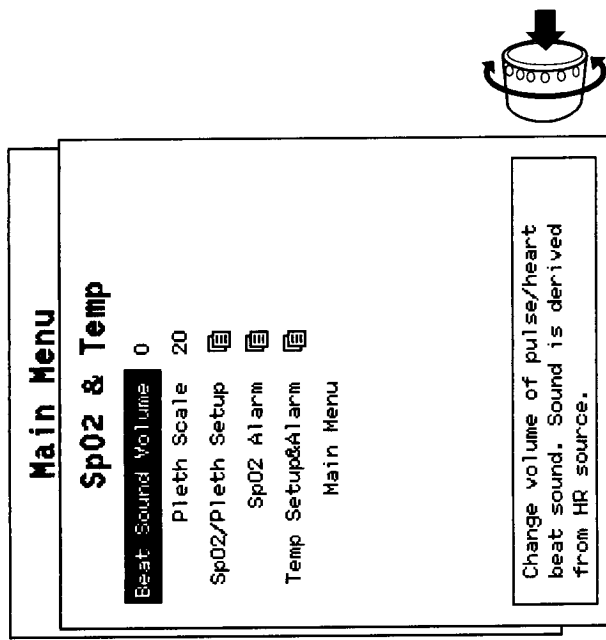

### Beat Sound Volume

Adjust beat volume from 0 to 10.

### Scale

Select Scale from **50, 20, 10, 5, 2** or use **AUTO** which automatically adjusts the scale according to the measured waveform.

### Sweep Speed

Set the speed of the display sweep for the waveform display. The speeds are **12.5, 25, or 50** mm/sec on a 9" screen.

**NOTE:** The sweep speed is same for ECG, plethysmographic, and invasive pressure waveforms.

### HR Source

Select the heart rate source. If ECG signal is too noisy for reliable heart rate calculation, heart rate can be calculated from pressure (**Art**) or pulse oximetry (**Pleth**). The heart rate source appears above the numerical display of the heart rate.

The **AUTO** (default) selects the source in the following order: ECG, pressure, and plethysmographic pulse waveform.

### SpO<sub>2</sub> Response

Select how fast the SpO<sub>2</sub> value follows the measurement. The selections are: **Beat-to-beat, Normal** (10 s), or **Slow** (20 s, default setting).

**SpO<sub>2</sub> Alarms** Opens a submenu for adjusting alarms, see the "Alarms" chapter.

**Temp Setup** Opens a submenu for adjusting temperature settings, see the "Temperature" chapter.

**Main Menu** Return to **Main Menu**.

## Setting SpO<sub>2</sub> alarms

The alarms can be adjusted in the **Alarms Setup** menu, accessed through the **SpO<sub>2</sub> & Temp** menu. See more detailed instructions in the chapter "Alarms."

Alarm messages are explained in the chapter "Maintenance and troubleshooting; Alarm and information messages."

## Measuring principle

Oxygen saturation, SpO<sub>2</sub>, expressed as a percent, defines the amount of oxygen carried compared to total capacity (also called functional or *in vivo* oxygen saturation). It is measured by a two wavelength pulse oximeter.

The SpO<sub>2</sub> value is measured by light absorption technique. Red and infrared light (660 nm and 910 nm) is emitted from the light source. The amount of transmitted light is detected in the detector half. When the pulsative part of the light signal is examined, the amount of light absorbed by arterial hemoglobins is resulted, and the saturation level can be calculated.

The saturation percentage is displayed numerically, and the pulse beep sound varies according to the saturation level.

### Plethysmographic pulse wave

The plethysmographic pulse wave is derived from variations of the intensity of the transmitted light and reflects the blood pulsation at the measuring site.

### Pulse rate

Pulse rate is calculated from the plethysmographic pulse wave.

## 17 Temperature

One temperature value can be measured from various sites using YSI-400 probes, or equivalents.



### Monitoring temperature

- Attach the probe to the patient.
- Connect the temperature probe to the connector on the right side of the monitor.
- The measured value appears on the digit field.

### Temperature display

Example:

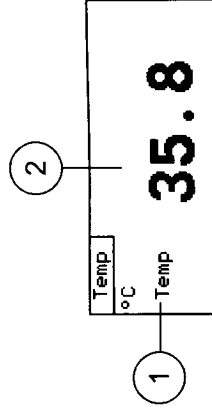

#### 17-1 Temperature display

- (1) Label
- (2) Temperature value

### Temperature testing

The monitor automatically tests the temperature measuring function at the start-up and after that every 10 minutes. If the test fails contact your local service representative.

### Temperature setup

- Press **Menu**.
- Select **SpO<sub>2</sub> & Temp**.
- Select **Temp Setup&Alarm**.

For your notes:



## 18 Non-invasive blood pressure (NIBP)



The monitor can measure NIBP automatically after set intervals, or take single measurements, or measure continuously for five minutes in STAT mode.

### WARNING

**PATIENT SAFETY:** The monitor sets the inflation pressure according to the previous measurement. Reset the monitor between patients to reset the inflation limit.

### CAUTION

Vibrations during transport may disturb the NIBP measurement.

## Monitoring NIBP

- Select the appropriate cuff and hose.
- 18-1 NIBP cuff sizes

Cuff	Color	Width		Limb circumference		Hose
		cm	inch	cm	inch	
Large adult	Red	15	6	33 - 47	13 - 18	Black
Standard adult	Blue	12	4.7	25 - 35	9 - 14	Black
Small adult	Gray	9	3.5	18 - 26	7 - 10	Black
Child	Green	6	2.4	10 - 19	4 - 7	Black
Infant	Tan	5.1	2	9 - 14	3 - 5	White
Disposable infant cuff #5		5.5	2.2	10 - 14	4 - 6	White

NOTE: Always use the white hose when measuring little children. Make also sure the **Inflation Limits** selection is set to **150 mmHg** or **Auto**.

## SpO2 & Temp

### Temp Setup & Alarm

Unit °C

Temp Label Temp

Temp Alarm

Previous Menu

Change temperature unit:  
°C or °F.

Unit

Selects unit, °C or °F.

Temp Label

Select the label:

- AirW** airway temperature
- Axil** axillary temperature
- Blad** bladder temperature
- Eso** esophageal temperature
- Myo** myocardial temperature
- Naso** nasopharyngeal temperature
- Rect** rectal temperature
- Room** room temperature
- Skin** skin temperature
- Temp** temperature
- Tymp** tympanic temperature
- Core** central temperature
- Surf** surface temperature

Previous Menu Return to SpO2 & Temp menu.

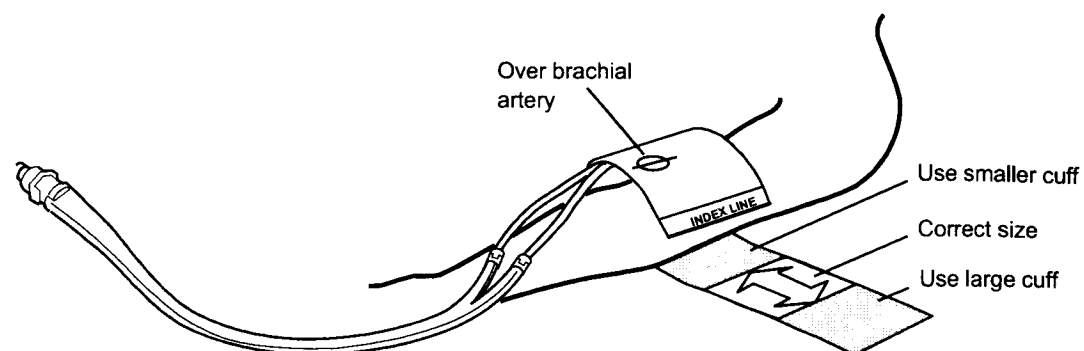

- Attach the cuff to the patient and the hose to the NIBP connector located on the right side panel of the monitor.
- Make sure that NIBP tubes are not bent, pressed or stretched. Measurement may be impaired.
- Press the **NIBP** key to open the NIBP mini menu.
- Select **Start Cycling** or **Start Manual** and press the ComWheel.
- You can also adjust the cycling time by selecting **Set Cycle Time**. Adjust the time by turning and pressing the ComWheel.
- Observe the cuffed limb frequently. The measurement may impair blood circulation. Intervals below 10 minutes and STAT measurements are not recommended for extended periods of time.

### Display of NIBP measurement

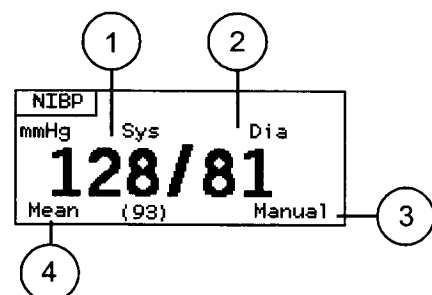

- (1) Systolic pressure
- (2) Diastolic pressure
- (3) Field shows the selected measurement (Manual, STAT), or the time since last autocycle measurement
- (4) Mean pressure value of non-invasive blood pressure

At the beginning of the measurement the cuff pressure is displayed in the mean pressure value field.

If motion artifacts are detected, the monitor automatically retains deflation until the motion stops (maximum of 30 seconds). If the artifacts interrupt proper measurement, a new measurement is automatically activated.

When the measurement is ready, a short beep is heard and the result starts flashing.

### Automatic NIBP double check

If the NIBP value exceeds the alarm limits, a new measurement is taken automatically (immediately, with MANUAL measurements, and after 30 seconds, with AUTO measurements). If an alarm situation persists, an alarm signal is given out.

### Using NIBP functions

To use NIBP functions:

- Press the **NIBP** key to open the NIBP mini menu

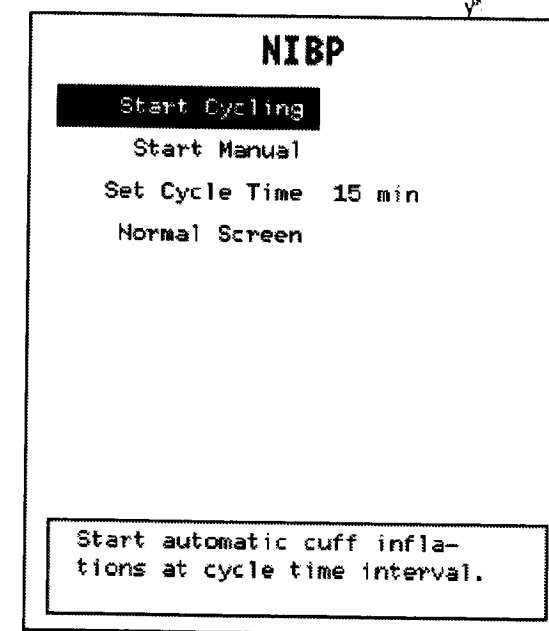

or

- Press **Menu** and select **NIBP & Inv. Press** to open the **NIBP & Inv. Pressure** menu.

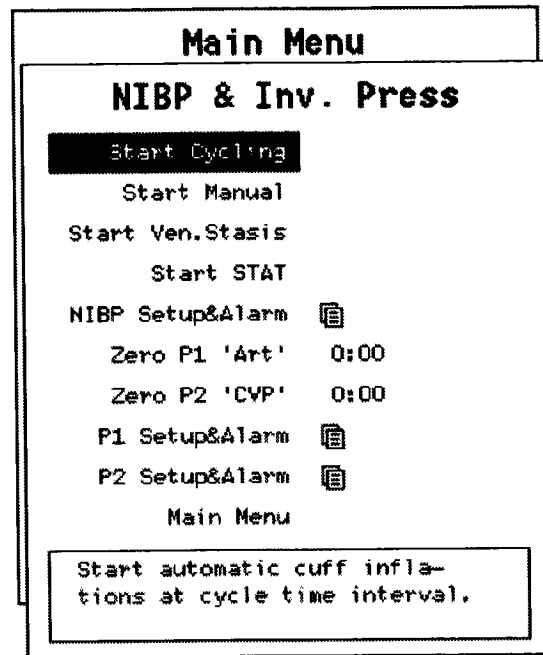

Starting/Stopping Autocycle, Starting a Manual Measurement and Canceling Any Measurement are available through both menus. STAT mode and Venous Stasis are available through the **NIBP & Inv. Pressure** menu only.

### Starting/Stopping autocycle

- Select **Start Cycling/Stop Cycling** to start/stop automatic NIBP measurement at selected intervals.

The bar at the bottom of the NIBP display shows the time remaining to the next measurement.

Autocycling is synchronized to actual time so that if the first measurement happens at 12.02, the next measurement is done at 12.05 and again at 12.10 (5 min intervals).

### Starting a manual measurement

- Select **Start/Stop Manual**.

### Canceling any measurement

- Press the **NIBP** key or
- select the corresponding menu item.

### Starting a continuous measurement (STAT)

You can start the continuous measurement for five minutes (STAT mode) through the **NIBP & Inv. Pressure** menu only.

In STAT mode the early systolic value is measured and displayed until the final result is available.

After five minutes the monitor automatically returns to the previously selected cycling interval or to manual mode.

To start the measurement:

- Press the **Menu** key and select **NIBP & Inv. Press**.
- Select **Start STAT**.

### Using venous stasis

You can hold a constant pressure in the cuff to help venous cannulation (Venous Stasis). This function is only available through the **NIBP & Inv. Pressure** menu. The pressure is maintained in the cuff for a certain time according to the inflation limits.

#### 18-2 Inflation limits and venous stasis times

Inflation limit	Venous stasis pressure	Venous stasis time
150 mmHg	40 mmHg	1 min
200 mmHg	60 mmHg	2 min
280 mmHg	80 mmHg	2 min

The pressurization time is displayed in the NIBP field and during the last 15 seconds the word 'STASIS' is flashed.

- Press the **Menu** key.
- Select **NIBP & Inv. Press** and **Start Ven. Stasis**.

To release the pressure before the time is expired:

- Press the **NIBP** key.

## NIBP adjustments

NIBP & Inv. Press	
NIBP Setup&Alarm	
Set Cycle Time	15 min
Ready Prompt	5
Inflation Limits	AUTO
Calibration Check	OFF
NIBP Alarm	
Previous Menu	

Change interval between automatic cuff inflations (mins).
---

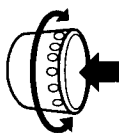

- Set Cycle Time** Select desired interval time of 1, 2.5, 3, 5, 10, 15, 30, or 60 minutes.
- Ready Prompt Vol.** Adjust the volume of the beep that informs when the NIBP measurement is ready. The range is from 1 (soft) to 10 (loud), or 0 (OFF).
- Inflation Limits** Select the inflation pressure limit: **280**, **200**, or **150** mmHg.
- Calibration Check** Start the pressure calibration check with an external manometer. See instructions below.
- NIBP Alarm** Opens a submenu for adjusting the NIBP alarms, see the "Alarms" chapter.
- Previous Menu** Return to the **NIBP & Inv. Pressure** menu.

## Calibration check

- Remove the cuff from the connector before entering the menu.
- Select **Calibration Check ON** in **NIBP Setup** menu.
- When the calibration menu appears, attach an external manometer with pump to the connector.
- Pump ca. 200 mmHg and compare the readings of the manometer and display. If the difference is greater than 4 mmHg, the calibration must be checked by an authorized service person.

## NIBP alarms

NIBP Alarms are set in the **Alarm Setup** menu, see the "Alarms" chapter. The alarm messages are explained in chapter "Maintenance and troubleshooting."

## Measuring principle

The non-invasive blood pressure (NIBP) measurement uses the oscillometric measuring principle. The cuff is inflated with a pressure slightly higher than the presumed systolic pressure, then slowly deflated at a speed based on the patient's heart rate, collecting data from the oscillations produced by the pulsating artery. Based on this data, the unit calculates values for systolic, mean and diastolic pressures.

For your notes:

## 19 Invasive blood pressure



Two invasive blood pressures can be measured with the model F-LMP1.

### WARNINGS

#### PATIENT SAFETY:

**All invasive procedures involve patient risks. Use the aseptic technique. Follow catheter manufacturer's instructions.**

**Ensure proper contact of the return electrode of the electrosurgery unit to your patient to avoid possible burns at sensor sites.**

**Make sure that no part of the patient connections touches any electrically conductive material including earth.**

**Use only defibrillator proof transducers and cables.**

### Monitoring invasive pressures

#### Preparing pressure line

- Prepare the transducer kit according to transducer manufacturer's instructions. Ensure there is no air in the line.
- Connect the kit to the transducer cable and the cable to the red connector in the monitor.
- Mount the transducer kit at heart level.
- Connect the patient catheter to the pressure line.
- Zero the transducer.
- Open the line to the patient.

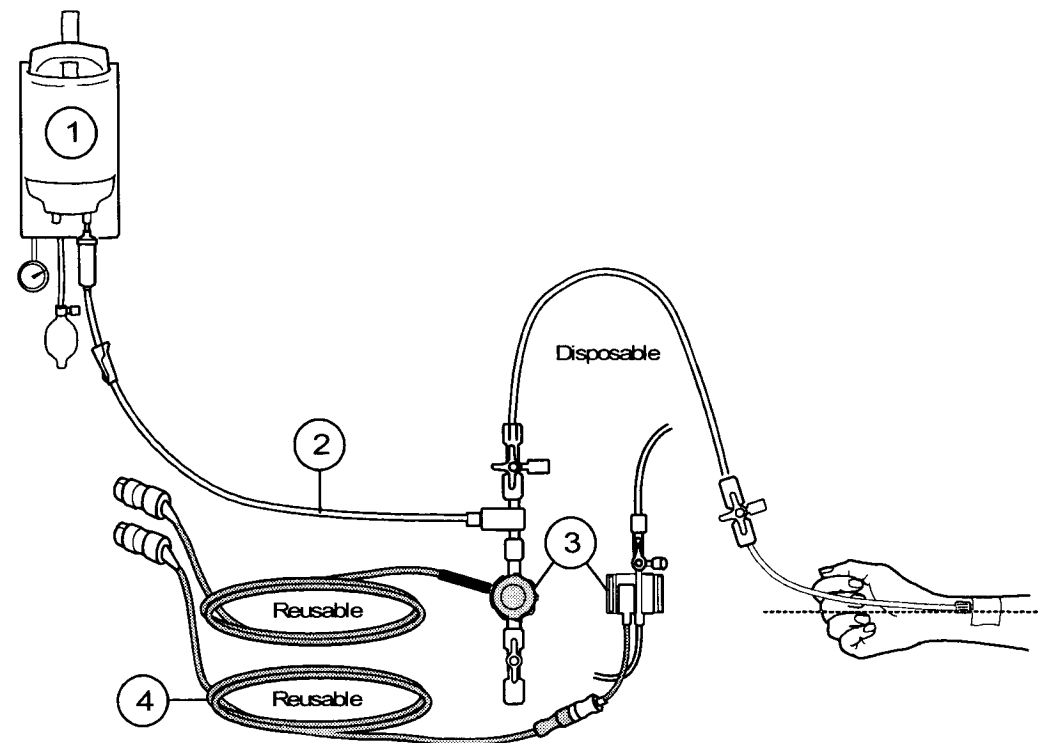

**19-1 Invasive pressure setup for disposable and reusable transducers**

- (1) Heparinized fluid bag with pressure infusor
- (2) Flushing set
- (3) Transducer
- (4) Adapter cable for using disposable transducers

### Zeroing transducer

Always zero the pressure transducer before monitoring and check zero level after power interruptions.

To zero the transducer:

- Open the transducer to air.
- Press the **Zero ALL** key or select **Zero Px** in the **NIBP & Inv. Pressure** menu.

The messages 'Zeroing' and 'Zeroed' are displayed accordingly. After the channel is zeroed, the zeroing time appears in the menu. If the zeroing fails, the previous zero is used.

- Open the transducer to the patient.
- NOTE: ICP can be zeroed via the **NIBP & Inv. Pressure** menu only.

### CAUTION

Mechanical shock to pressure transducer may change zero balance and calibration.

### Invasive pressure display

After the line is zeroed and opened to the patient, the pressure wave appears.

If two pressures are measured they can be combined with individual scales. (Select separate or combined waveforms in the **Monitor Setup/ Waveform Fields** menu, see chapter "Monitor setup").

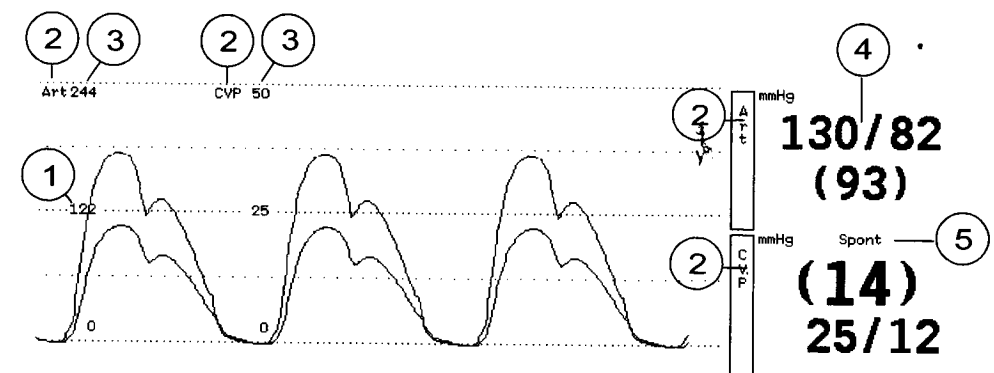

**19-2 Combined pressure waveforms**

- (1) Invasive blood pressure waveforms with zero and reference lines
- (2) Selected pressure label
- (3) Selected pressure scale
- (4) Systolic, diastolic and mean pressures
- (5) Ventilation mode selected in the **Px Setup&Alarm** menu

### Adjustments

- Press **Menu**.
- Select **NIBP&Inv. Press**.
- Select **Px Setup&Alarm**.

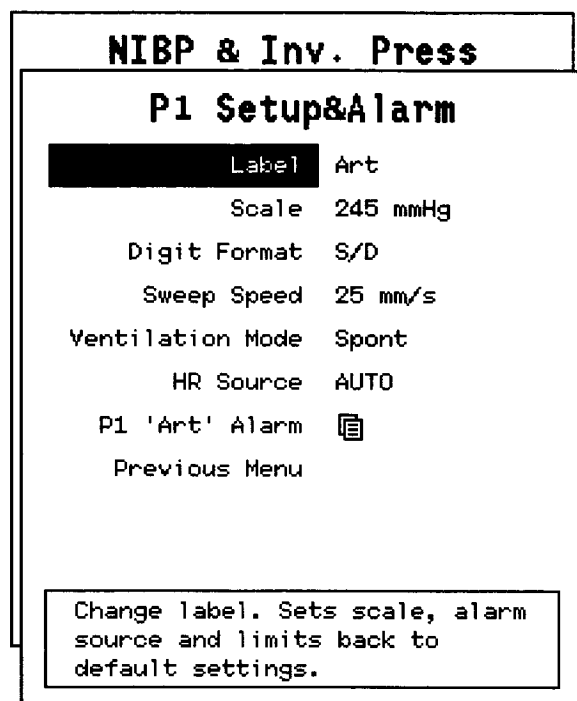

### Labeling the invasive line

The label of the pressure channel sets its scale, alarm source and alarm limits. The label alternatives are:

- P1, P2** Standard labels
- Art** Arterial pressure
- CVP** Central venous pressure
- PA** Pulmonary arterial pressure
- ICP** Intracranial pressure

To change the label

- Go to setup menu of the desired pressure.
- Select Label.
- Select the desired label from the list.

### 19-1 Waveform scales, alarm sources and limits that are assigned when the label is selected

Label	P1, Art	P2, CVP	PA	ICP
Scale (mmHg)	200	20	60	20
Alarm source	sys	off	off	off
Digit format	S/D	Mean	S/D	Mean
Filter (Hz)	22	9	9	9

### Changing the scale

Scales can be adjusted between 10 and 300 mmHg in steps of 10.

- Go to setup menu of the desired pressure.
- Select **Scale**.
- Adjust the scale by turning and pressing the ComWheel.

### Other invasive pressure setup adjustments

**Digit Format** Select the displayed digit, either, systole and diastole (**S/D**) or **Mean**.

**Sweep Speed** Set the display sweep speed for the waveform display. The speeds are: **12.5**, **25**, or **50** mm/sec.

NOTE: The sweep speed is same for ECG, plethysmographic, and invasive pressure waveforms.

#### Ventilation Mode

Select **Spont** or **Contrl** for spontaneous or controlled ventilation. Respiration may cause artifacts in invasive pressure measurement.

#### HR Source

Select the heart rate source. If the ECG signal is affected by too much noise for a reliable heart rate calculation, heart rate can be calculated from pressure (**Art**) or Plethysmographic pulse waveform (**Pleth**). The selected heart rate source is shown above the numerical display of the heart rate.

**AUTO** selects the first available of: ECG, Art, and Pleth.

#### Px Alarm

Opens a submenu for adjusting Alarm settings, see the "Alarms" chapter.

**Previous Menu** Return to the **NIBP & Inv. Pressure** menu.

## Invasive pressure alarms

Invasive pressure alarm is active only after pressure channel has been zeroed.

For alarm setup, see the "Alarms" chapter.

Alarm messages are explained in the chapter "Maintenance and troubleshooting."

## Measuring principle

The transducer converts the pressure variations into electrical signals. The electrical signals are amplified and displayed as numeric pressure values and waveforms.

## 20 Carbon dioxide, CO<sub>2</sub>

CO<sub>2</sub> can be measured with mainstream method (N-LCM option) using Mainstream CO<sub>2</sub> Sensor and airway adapter.

Respiration rate is the frequency of the peak (end tidal) CO<sub>2</sub> value per minute.

### Monitoring mainstream CO<sub>2</sub>

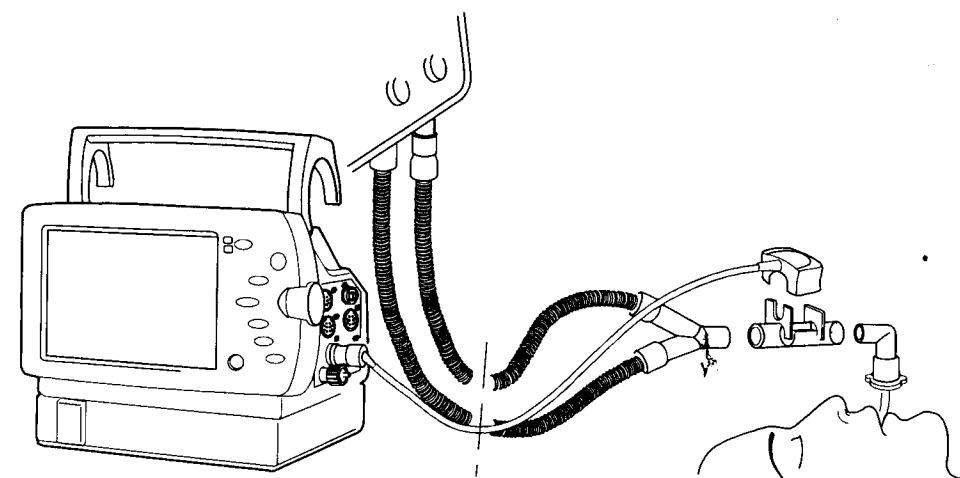

#### 20-1 Connecting mainstream CO<sub>2</sub> sensor

1. Connect the special airway adapter between the elbow adapter and Y-piece with the saddles upright.
2. Attach the Mainstream CO<sub>2</sub> Sensor to the adapter between the saddles so that the sensor cable fits into the slot on the farther saddle. Ensure the connection between the sensor and the adapter with the Velcro tape supplied with the sensor.



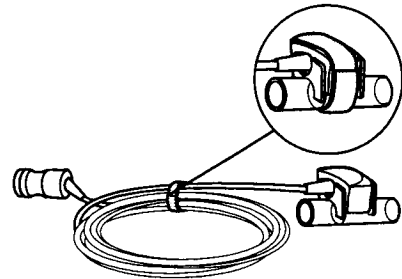

3. Connect the sensor to the connector on the monitor's side panel.

Place the adapter as close to the patient airway as possible. Make sure that the sensor remains in upright position.

To remove the adapter:

- Detach the sensor before removing the adapter from the circuit.

#### CAUTION

Do not apply force to the sensor or sensor cable.

Select the airway adapter according to the patient's status. Refer to the instructions for use provided in the adapters package.

Using the adult/pediatric mainstream airway adapter (endotracheal diameter  $\geq 5.5$  mm) increases the dead space by 6 ml. With the low dead-space airway adapter (diameter  $< 5.0$  mm), the increase is 0.6 ml.

NOTE: Airway adapter selection recommendations should be used as a guideline. It is important for the clinician to assess each patient when selecting the appropriate airway adapter.

#### WARNINGS

Do not allow the CO<sub>2</sub> sensor to come in contact with the patient's skin for a prolonged period of time. Mainstream sensor is heated to prevent the fogging of the airway windows.

Do not immerse the sensor in liquids or autoclave it.

Do not use damaged sensors or adapters.

Do not clean or sterilize a single use adapter.

## Display of CO<sub>2</sub> measurement

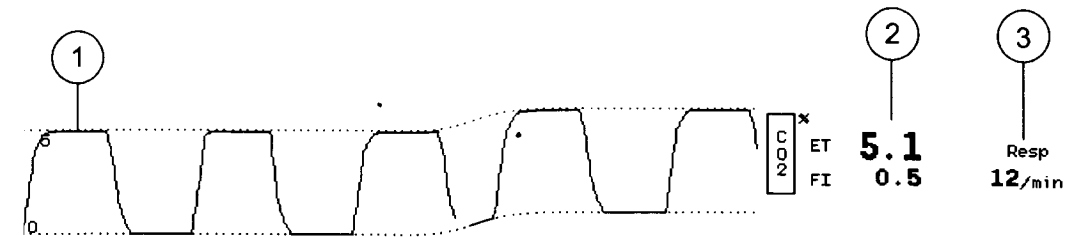

20-2 Display of the CO<sub>2</sub> waveform

- (1) Continuous CO<sub>2</sub> waveform
- (2) Values of end tidal (ET) and fraction of inspiratory (FI) CO<sub>2</sub>
- (3) Respiration rate

## CO<sub>2</sub> adjustments

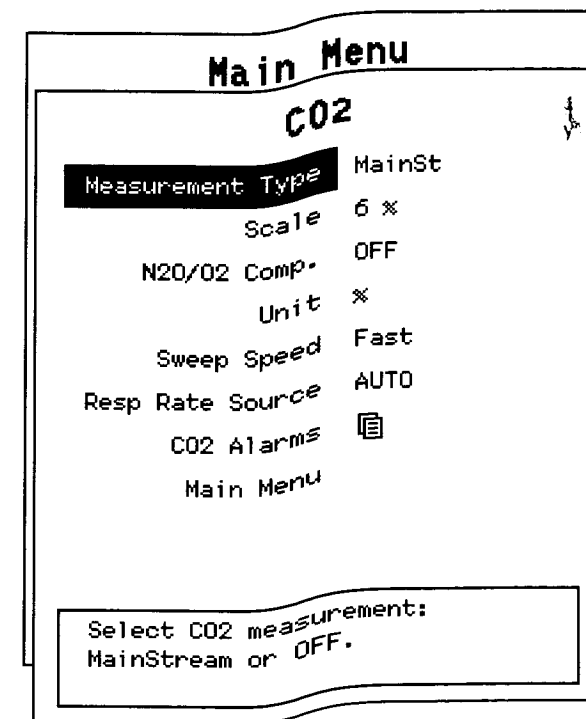

#### Measurement

Set on mainstream (**MainSt**) or turn the measurement **OFF**.

**Scale** Selects 0 - 6%, 0 - 10%, 0 - 15%, or kPa and 0 - 50 mmHg, 0 - 80 mmHg, 0 - 100 mmHg. Scale 0 - 6% is used in normal situations, 0 - 10% and 0 - 15% scales are used if hypercarbia is expected.

**N2O/O2 Comp** Selects compensation: **OFF**, **N2O** or **O2**. In the breathing circuit when there is 50% or more of N2O, use N2O compensation; when there is 60% or more of O2, use O2. In other cases, turn off the compensation.

**Unit** Selects CO2 unit: **%**, **kPa** or **mmHg**. See "Unit conversions" later in this chapter.

**Sweep Speed** Selects **Fast** (6.25 mm/sec) or **Slow** speed (0.62 mm/sec). Slow waveforms have a sweep speed one tenth of normal, for a full screen sweep (five minutes). Slow waveforms show changes better than fast waveforms.

**Resp Rate Source** Change respiration rate source: **AUTO**, **CO2** or **impedance respiration**.

**CO2 Alarm** Brings you to the **Alarms Setup** menu to adjust CO2 alarms.

**Main Menu** Returns you to the **Main Menu**.

## Calibration check

No routine calibration by user is required. Calibration check is recommended to be performed once a year by a qualified technical personnel. See the "Technical Reference Manual" for instructions.

## Unit conversions

Relationship between gas concentration and its partial pressure:  
reading in mmHg = (ambient pressure mmHg \* gas concentration in %) / 100

reading in kPa = (ambient pressure in mmHg \* gas concentration in %) / 750

## Measuring principle

The CO2 measurement is based on the infrared absorption. In the mainstream method the measurement bench is located at the patient's airway adapter.

## Maintenance and Specifications

21 Maintenance and Troubleshooting .....	113
22 General Specification .....	129
23 Accessories .....	139

## 21 Maintenance and troubleshooting

### WARNING

**ELECTRICAL SHOCK HAZARD: Do not remove cover. Refer servicing to qualified service personnel.**

### Maintenance

#### Once a month

- Clean the rear panel dust filter, see the "Cleaning" chapter.
- Discharge and recharge the batteries fully every three months.

#### Once a year

- Check the CO<sub>2</sub> calibration, see "Technical Reference Manual."

### Checklist

Check the following items to ensure you have remembered the essential preparations before monitoring or if any problems occur during monitoring.

If the monitor does not function as it should and troubleshooting cannot solve the problem, contact your sales representative. Qualified service personnel may use the "Technical Reference Manual."

### General

Check that the

- monitor doesn't have any visual defects, such as cracks or loose parts.
- power cord with external power adapter is connected to a grounded electrical wall outlet and the voltage selector is set to local voltage.
- patient connection cables are attached to the monitor so that the color coding on the plug matches the color coding on the monitor connector.
- trends of the previous patient are erased.
- alarm limits are suitable for a new patient.
- monitor is used in correct environmental conditions, see "General specifications."

**ECG/Respiration**

Check that the

- electrode gel is moist.
- electrodes have good skin contact.
- electrodes are positioned correctly.
- correct cable is used: 5-lead cable with 5 lead sets and 3-lead cable with 3-lead sets. (If you have a 3-lead set connected to a 5-lead trunk cable, you must set in the **ECG Setup** menu the selection **5 Lead Cable** to **3elect**).
- ECG trunk cable is connected to the blue connector.
- leadwire set is properly connected to the trunk cable.
- Pacemaker selection in the **ECG Setup** menu is **Show** or **ON R** when a pacemaker is used.
- ECG/Respiration is selected for display in the **Monitor Setup** menu.

For the respiration measurement:

- **PACEMAKER PATIENTS:** The impedance respiration measurement may cause rate changes in Minute Ventilation Rate Responsive Pacemakers. Set the pacemaker rate responsive mode off or turn off the impedance respiration measurement on the monitor.

**Pulse oximetry**

Check that the

- correct SpO<sub>2</sub> sensor is selected for each patient size.
- sensor is completely dry after cleaning.
- SpO<sub>2</sub> extension cable is connected to the gray connector.
- sensor cable is properly connected to the extension cable.
- sensor is positioned correctly to the patient and the measuring site is well prepared.
- SpO<sub>2</sub> is selected for display in the **Monitor Setup** menu.

**Temperature**

Check that the

- temperature probe is YSI-400 or equivalent.
- temperature probe is inserted properly into the connector.
- temperature is selected for display in the **Monitor Setup** menu.
- temperature probe is positioned correctly.

**Non-invasive blood pressure NIBP**

Check that

- the O-rings on hose connectors are intact, two at monitor side.
- the NIBP hose is properly connected to the monitor and will not come loose by pulling.
- the correct NIBP cuff size is used.
- the right hose (black or white) is used for different cuffs.
- the O-ring on cuff connector is intact and the connector firmly pushed inside the cuff tube.
- there are no holes or cracks in the cuff bladder or cuff tube.
- the symbol indicating the center of the bladder is over the artery.
- all residual air is squeezed out of the cuff before wrapping it around the arm.
- the cuff is not loose.
- the cuff is at heart level.
- the tubes are not bent, pressed or stretched.
- if a leak is suspected, start venous stasis and check that the pressure is stable during stasis.
- non-invasive blood pressure is selected for display in the **Monitor Setup** menu.

**Invasive blood pressure**

Check that

- invasive blood pressure transducer cable is connected to a red connector.
- the pressure transducer is connected to the cable.
- the patient catheter is connected to the pressure line.
- there are no air bubbles in the transducer dome or catheter line.
- the transducer is at mid heart level.
- the pressure transducer is zeroed.
- invasive blood pressure is selected for display in the **Monitor Setup** menu.

**CO<sub>2</sub>**

Check that

- the measurement is set on.
- the sensor is properly attached to the airway adapter. Ensure the connection with the Velcro tape supplied with the CO<sub>2</sub> sensor.
- the sensor is connected to the monitor.
- a new airway adapter is used for each patient. Used adapters may leak and cause too high CO<sub>2</sub> values.

**Battery packs and Module**

Check that

- battery packs are properly inserted in the module.
- charging LEDs are lit when batteries are fully charged/ flashing during charging / not lit when the monitor is battery driven.
- battery operation with a fully charged battery lasts at least one hour. If not, the battery is old and needs to be replaced.

NOTE: Discharging and recharging the battery regularly lengthens the battery lifetime.

**Alarm and information messages****ECG****Alarms**

Messages	Explanation
Asystole	No QRS complexes in 6 sec. Asystole message is given always from ECG in spite of HR calculation source and only from ECG.
HR high/low	Measured heart rate exceeds the alarm limit.
Leads off	ECG cable, or some or all leads are off. Possibly the DC offset voltage between two electrodes is too high. 3-lead set is used with a 5-lead cable; set in <b>ECG setup</b> menu the selection <b>5 Lead Cable</b> to <b>3elect</b> . If 5-lead trunk cable is used with 3-lead set and 3elect is not chosen from the ECG&resp menu, the audible alarms and heart rate calculation are not activated.

**Notes**

Messages	Explanation
Leads off	ECG cable, or some or all leads are off. Possibly the DC offset voltage between two electrodes is too high. 3-lead set is used with a 5-lead cable; set in <b>ECG setup</b> menu the selection <b>5 Lead Cable</b> to <b>3elect</b> . If 5-lead trunk cable is used with 3-lead set and 3elect is not chosen from the ECG&resp menu, the audible alarms and heart rate calculation are not activated.
Noise	High frequency noise, e.g. from electrosurgical unit, or 50 Hz from the mains.
Artifact?	Frequent ECG overload or clipping <ul style="list-style-type: none"> <li>- Elevated baseline noise</li> <li>- Heart rate &gt; 240</li> </ul>
Casc.	Two ECG waveforms selected for display.

**Impedance respiration**

**Alarms**

Messages	Explanation
Apnea	No breathing detected for 20 seconds.
Resp high/low	Measured respiration rate exceeds the alarm limit.

**Notes**

Messages	Explanation
Leads off	Cable, or some or all the leads off. Possibly the DC offset voltage between two electrodes is too high.
Measurement off	Measurement has turned off.
Small Resp curve	Signal amplitude < 0.4 Ohm.

**Invasive blood pressure**

**Alarms**

Messages	Explanation
P1 (P2) High/Low	Measured P1 (P2) exceeds the alarm limit
HR High/Low	Measured heart rate exceeds the alarm limit.

**Notes**

Messages	Explanation
No P1 (P2) Transducer	Transducer is not connected.
No Transducer	Transducer is not connected.
Not zeroed	Measurement on, channel is not zeroed.
Zeroing	Zeroing of P1 (P2) in progress.
Zeroed	P1 (P2) zeroed; message time-out 10 seconds.
Zeroing failed	Unsuccessful zeroing of P1 (P2). Retry.
Failed	Unsuccessful zeroing of P1 (P2). Retry.
Zero ICP via menu	ICP must be zeroed through menu.
Zero fail. Prev P1 (P2) zero valid	Zeroing failed. Previous zero value will be used.
Calibrating	Calibrating of P1 (P2) in progress.
Calibrated	P1 (P2) transducer calibrated; message time-out 10 seconds.
Calibration failed	Unsuccessful calibrating of P1 (P2).
Failed	Unsuccessful calibrating of P1 (P2).
Out of range	Measured pressure exceeds > 320mmHg or < -40 mmHg.
Zero adj >100mmHg	Offset over 100 mmHg, reduced range.

**NIBP**

**Alarms**

Messages	Explanation
NIBP High/Low	Measured NIBP value exceeds the alarm limit.
(NIBP) Cuff occlusion (with message beep, then caution beep)	Cuff remains pressurized after measurement or becomes pressurized during or between measurements for more than 15 seconds.
(NIBP) Cuff loose, NIBP manual (if cycling stopped)	Cuff not attached to patient or too loose. Hose not connected to the monitor. Measuring mode is changed to manual.
Air leakage (+beep)	Air leakage in cuff or hose, in one of the connectors or inside the module. Measuring mode is changed to manual.
NIBP Air leakage, NIBP manual (if cycling is stopped)	Air leakage in cuff or hose, in one of the connectors or inside the module. Measuring mode is changed to manual.

**Notes**

Messages	Explanation
Artifacts	Unsuccessful NIBP measurement due to: <ul style="list-style-type: none"> <li>- movements</li> <li>- shivering</li> <li>- deep breathing</li> <li>- marked arrhythmia or irregular beats</li> </ul>
Weak pulsation	Weak pulsation's due to: <ul style="list-style-type: none"> <li>- improper cuff position</li> <li>- weak or abnormal circulation</li> <li>- slow heart rate associated with artifacts</li> <li>- problems with measuring diastolic pressure</li> <li>- small air leakage</li> <li>- insufficient data to artifacts</li> </ul>
Cuff overpressure	Cuff is squeezed during measurement and exceeds pressure safety limits. Measurement is canceled and safety valves are opened. Message stays 10 seconds.
Unable to measure Sys	Systolic pressure probably higher than maximum inflation pressure or artifacts in systolic area. Automatic retrial with increased pressure. Message stays 10 seconds.
Unable to measure Dia	Artifacts, accurate diastolic pressure difficult to measure. Message stays 10 seconds.
Unstable zero pressure (+beep)	Unstable zero pressure when cuff is inflated. New measurement in correct time. Measurement stays 10 seconds.
Inf. limits! Check setup (+beep)	Adult or child cuff is used, but the selected infant mode restricts the inflation pressure too low to be able to measure the blood pressure. Message stays 10 seconds.
Long measurement time (+beep)	Measurement time over two min (adult and child mode) and one min (infant mode). Message stays 10 seconds.

Messages	Explanation
Wait for the measurement to be done	When measurement is going and VENOUS STASIS is attempted.
Control measurement	Pressure alarm limit is exceeded. New measurement is performed automatically to check the blood pressure. Message stays 10 seconds.
Call service. Error X (+beep)	NIBP hardware error. Contact authorized service personnel. x = error number 1-99. Message stays on the screen. See "Technical Reference Manual."

### Temperature

#### Alarms

Messages	Explanation
Temp High	Measured temperature value exceeds the alarm limit.

#### Notes

Messages	Explanation
Performing temp test	During the calibration test.
Temperature error	Error message if calibration test fails.

### Pulse oximetry

#### Alarms

Messages	Explanation
SpO <sub>2</sub> probe off	Sensor is not connected to the patient.
No SpO <sub>2</sub> pulse	No pulse detected during last 20 seconds or more.
Faulty probe	Damaged probe, probe is present but LEDs take no current.

#### Notes

Messages	Explanation
Probe off	Sensor is not connected to the patient.
No pulse	Pleth pulses not detected.
Artifact	Interference due to movements or shivering.
Check Probe	Probably faulty sensor or wrong attachment.
Poor signal	Check the sensor site for poor blood circulation. Change site and sensor if needed.
Scale changed	Pleth scale changed automatically, 10 s time-out.
SpO <sub>2</sub> Low	SpO <sub>2</sub> ≤ alarm limit
SpO <sub>2</sub> High	SpO <sub>2</sub> ≥ alarm limit
HR Low	Pulse rate ≤ alarm limit
HR High	Pulse rate ≥ alarm limit
No SpO <sub>2</sub> probe	Sensor is not connected to the monitor.
No probe	Sensor is not connected to the monitor.
Pulse search	Searching for appropriate internal gain (and signal levels).
No SpO <sub>2</sub> pulse?	No pulse detected when the Pleth is selected as HR source.
SpO <sub>2</sub> probe?	No pulse detected when ECG or Art selected as HR source.

### CO<sub>2</sub>

#### Alarms

Messages	Explanation
Resp high/low	Measured respiration rate exceeds the alarm limit.
EtCO <sub>2</sub> high/low	Measured EtCO <sub>2</sub> exceeds the alarm limit.
FiCO <sub>2</sub> high	Measured FiCO <sub>2</sub> exceeds the alarm limit.
Apnea	No breathing detected for 20 seconds.
No CO <sub>2</sub> Sensor	Mainstream sensor not been connected.



Messages	Explanation
CO <sub>2</sub> sensor Failure	CO <sub>2</sub> sensor malfunctioning.
Unspecified CO <sub>2</sub> Sensor?	A non-Datex-Ohmeda sensor used.
Use only Datex-Ohmeda mainstream CO <sub>2</sub> Sensor	Unspecified CO <sub>2</sub> sensor detected for more than 30 seconds.
Gas module error	CO <sub>2</sub> measuring failure, contact authorized service.
Clean airway adapter	CO <sub>2</sub> sensor airway adapter foggy or dirty.
Clean or replace mainstream CO <sub>2</sub> airway adapter.	Blocked airway adapter detected > 30 s.

**Notes**

Messages	Explanation
Warming	CO <sub>2</sub> sensor warming up.
O <sub>2</sub> Compensation	O <sub>2</sub> compensation selected ON.
N <sub>2</sub> O Compensation	N <sub>2</sub> O compensation selected ON.
Over Scale	Waveform is over the selected scale.
Measurement Off	CO <sub>2</sub> measurement is selected OFF.

**DataCard**

**Notes**

Messages	Explanation
Faulty Data Card - change card	DataCard read/write error.
Data Card full	DataCard full of data.
Data Card inserted	DataCard is inserted in the card slot.

Messages	Explanation
Data Card removed	DataCard is removed from the card slot.
Insert Data Card	DataCard is not present during case.
Faulty Data Card: change card	MenuCard or some other card is inserted in the slot.

**Battery**

**Alarms**

Messages	Explanation
Batt Low	<b>Note:</b> Less than 10 min of battery time available. <b>Yellow Alarm:</b> Less than 2 min of battery time available.

**Notes**

Messages	Explanation
Batt too warm to charge	Battery temperature > +40°C
Batt too cold to charge	Battery temperature < +10°C

**Recorder**

**Notes**

Messages	Explanation
Recorder: out of paper	No paper in recorder.
Recorder: cover open	Recorder cover is open.
Recorder: thermal array overheat	Thermal array is overheated, recorder does not function.

Messages	Explanation
Recorder: Input voltage low	Input voltage is too low, recorder does not function.
Recorder: Input voltage high	Input voltage is too high, recorder does not work.
Recorder: System error xx	Error in recorder.

**Other messages**

Messages	Explanation
Monitor temp high. Vent OK?	The temperature inside the monitor is too high. Check ventilation.
STP module error	Error in STP measurement communication.
ECGR module error	Error in ECGR measurement communication.
NIBP module error	Error in NIBP measurement communication.
CO2 module error	Error in CO <sub>2</sub> measurement communication.
Case Started	Vital signs have been detected.
Case Ended	Vital signs are not detected any longer.
RAM Error	RAM error detected.
SRAM Error	SRAM error detected.
FLASH Error	FLASH error detected.
Printing...	Printing is active.
Printer failure	Failure in printer.

**Troubleshooting**

What if...	Try this:
CO <sub>2</sub> readings are unreliable.	Check that the sensor is properly attached to the adapter. Ensure the connection with the Velcro tape supplied with the CO <sub>2</sub> sensor.
ECG signal is noisy, or no QRS is detected.	<ul style="list-style-type: none"> <li>• Ensure that the patient is not shivering.</li> <li>• Check electrodes quality, positioning and skin contact.</li> <li>• Change lead.</li> <li>• Enlarge the size from 1.0 mV to 2.0 mV.</li> </ul>
Invasive blood pressure readings are unreliable.	<ul style="list-style-type: none"> <li>• Make sure that there are no air bubbles in transducer system. Flush and zero.</li> <li>• Place transducer on patient's mid-heart level, and zero.</li> </ul>
'Zeroing failed'-message is displayed, when the <b>Zero ALL</b> key is pressed.	Stopcock not opened to room air on all channels: Zero, or continue if the lines have been zeroed separately.
NIBP measuring does not work or values are unreliable.	<ul style="list-style-type: none"> <li>• Use cuffs of correct size and check that cuff tubings are not bent, stretched, compressed or loose.</li> <li>• Prevent motion artifacts.</li> <li>• Make sure that the patient is not shivering.</li> </ul>
Respiration measurement fails.	<ul style="list-style-type: none"> <li>• Check electrode quality and positioning.</li> <li>• Adjust the detection limits.</li> </ul>
SpO <sub>2</sub> signal is poor.	<ul style="list-style-type: none"> <li>• Check sensor placement.</li> <li>• Be aware of differences caused by skin pigment.</li> <li>• Make sure that the patient is not shivering.</li> </ul>
Temperature measuring fails	<ul style="list-style-type: none"> <li>• Check that you have the correct kind of probe. Try another probe.</li> </ul>
The monitor does not start.	The power cord is not connected: <ul style="list-style-type: none"> <li>• Connect the power cord to the power outlet.</li> </ul> Battery empty: <ul style="list-style-type: none"> <li>• Replace battery with a recharged one.</li> </ul> Fuses blown: <ul style="list-style-type: none"> <li>• Check the fuses, replace if necessary or contact your local service.</li> </ul>
Monitor is very warm.	Dust filter is blocked: <ul style="list-style-type: none"> <li>• Clean or replace the back panel dust filter.</li> </ul>

What if...	Try this:
Batteries are not recharged.	Batteries are not properly inserted, power supply not connected, or monitor too warm or cold: <ul style="list-style-type: none"> <li>• Wait for monitor to cool down/warm up. Recharge only in room temperature.</li> </ul>
Battery operation lasts less than specified.	Batteries are not fully charged: <ul style="list-style-type: none"> <li>• Charge batteries fully, and check operation.</li> </ul> Battery pack is faulty, or too old: <ul style="list-style-type: none"> <li>• Replace the battery pack with a new one.</li> </ul>
'Batt Low'-message.	Less than 10 min of battery time left: <ul style="list-style-type: none"> <li>• Replace with fully charged batteries, or plug in the power cord.</li> </ul>

## 22 General specifications

### WARNING

Operation of the monitor outside the specified values may cause inaccurate results.

### Parameter specifications

#### ECG

Measured leads: I, II or III  
 Frequency response: 0.5 to 30 Hz (-3 dB, with 50 Hz reject filter)  
 0.5 to 40 Hz (-3 dB, with 60 Hz reject filter)  
 Sweep speed: 12.5, 25, or 50 mm/s

#### Heart rate/Pulse rate

Measurement range: 30 to 250 bpm  
 Measurement accuracy:  $\pm 5\%$  or  $\pm 5$  bpm whichever is greater  
 Display resolution: 1 bpm  
 Averaging time: 10 s  
 Display update time: 5 s  
 QRS minimum detection level: Minimum level 0.5 mV with duration between 40 and 120 ms fulfils ANSI/AAMI EC13 standard.  
 Alarms: asystole, leads-off detection, adjustable high and low alarm limits for heart rate  
 Gain range: 0.2 to 5.0 cm/mV  
 Allowable DC differential offset:  $\pm 300$  mV  
 Pacemaker pulse detection: detection level: 5 to 500 mV, pulse duration: 0.5 to 2 ms

**Impedance respiration**

Measuring range:	Impedance, 0.2 to 6 Ohm
Max. base impedance:	5 kOhm
Respiration range:	4 to 120 resp/min
Accuracy:	± 5% or ± 5 resp/min whichever is greater
Averaging:	30 s
Update interval:	10 s
Display resolution:	1 resp/min
Sweep speed (trace):	slow 0.62 mm/s, fast 6.25 mm/s
Alarms:	apnea, adjustable high and low alarm limits for respiration rate
Gain range:	0.1 to 5 cm/Ohm

**Pulse oximetry (SpO<sub>2</sub>)/Pleth**

Measurement method:	red and infrared light absorption SpO <sub>2</sub>
Measurement range:	40 to 100%
Calibration range:	50 to 100%; calibrated against functional oxygen saturation
Display resolution:	1 digit (1% of SpO <sub>2</sub> )
Measurement accuracy <sup>*)</sup> :	100 to 80%, ± 2 digits (± 1SD) 80 to 50%, ± 3 digits (± 1SD) 50 to 40%, unspecified
Display averaging time:	adjustable 20 s, 10 s, or beat-to-beat
Display update time:	1 second
Display range:	40 to 100%
Wavelength of SpO <sub>2</sub> probe LEDs:	
Infrared LED:	900 nm
Red LED:	660 nm

**Pulse oximetry (SpO<sub>2</sub>)/Pleth**

Maximum energy of SpO <sub>2</sub> probe LEDs	
Infrared LED:	42 µJ/pulse
Red LED:	62 µJ/pulse
Alarms:	probe off, no probe, no pulse, adjustable high and low, alarm limits for SpO <sub>2</sub>

**Pulse rate**

Measurement range:	30 to 250 bpm
Display resolution:	1 digit (1 bpm)
Measurement accuracy:	± 5% or ± 5 bpm

Alarms: adjustable high and low alarm limits for pulse rate

**Plethysmographic pulse waveform**

Scales:	proportional scaling: 2, 5, 10, 20, 50 mod% or automatic scaling
---------	--

<sup>\*)</sup> Accuracy is based on deep hypoxia studies using Finger Sensors on volunteered subjects. Arterial blood samples have been analyzed by a Radiometer OSM Co-oximeter. Refer to the sensor instructions for specific SpO<sub>2</sub> accuracy.

**Temperature**

Measurement units:	°C or °F
Measurement range:	10 to 45 °C (50 to 113 °F)
Measurement resolution:	0.1 °C (0.1 °F)
Measurement accuracy:	± 0.1 °C (25 to 45.0 °C) ± 0.2 °C (10 to 24.9 °C)
Probe type:	Compatible with YSI 400 series

**Non-invasive blood pressure**

Measurement principle:	oscillometric with linear deflation		
Deflation speed:	heart rate dependent, 5 to 13 mmHg/s		
Measurement range:	adult 25 to 260 mmHg child 25 to 190 mmHg infant 15 to 140 mmHg		
Pulse rate range:	30 to 250 bpm		
Numeric display:	systolic, diastolic and mean arterial pressure		
Alarms:	cuff loose, cuff occlusion, adjustable high and low alarm limits for systolic, diastolic, mean or off		
Typical measurement time:	adult 23 s and infant 20 s		

<b>Safety features:</b>	<b>adult</b>	<b>child</b>	<b>infant</b>
Initial inflation pressure (mmHg):	185	150	120
Max. inflation pressure (mmHg):	280	200	150
Overpressure limit (max. 2 s; mmHg):	320	220	165
Max. inflation time (>13 mmHg, min):	2	2	1
Safety valve (mmHg):	320	220	165

**Invasive blood pressure (F-LMP1 models only)**

Measurement range:	-40 to 320 mmHg
Measurement accuracy:	± 5% or ± 2 mmHg
Numeric display	
Range:	40 to 320 mmHg
Resolution:	1 mmHg

**Invasive blood pressure (F-LMP1 models only)**

Averaging:	over 5 s or end-expiratory filtering
Display update:	every 5 s
Alarms:	adjustable high and low alarm limits for systolic, diastolic and mean pressures, or off

**Waveform display**

Range:	-30 to 300 mmHg
Scales:	adjustable in 10 mmHg increments

**Pulse rate**

Measurement range:	30 to 250 bpm
Resolution:	1 bpm
Accuracy:	± 5% or 5 bpm
Transducer sensitivity:	5 µV/mmHg, 5 Vdc, max.20 mA
Pressure filter:	22 Hz (-3 dB) for P1, Art 9 Hz (-3dB) for P2, CVP, PA, ICP

**CO<sub>2</sub> (option N-LCM)**

Principle of operation:	Non-dispersive infrared, single beam, single frequency, fully chopped, ratiometric
Measurement range:	0 to 99 mmHg / 0 to 13 vol-% / 0 to 13 kPa
Measurement rise time:	100 ms
Accuracy**)	0 to 40 mmHg / 0 to 5.3 vol-%: ± 2 mmHg / ±0.3 vol-% 41 to 76 mmHg / 5.3 to 10%: ± 5% of reading 77 to 99 mmHg / 10 to 13%: ± 10% of reading
Respiration rate measurement range:	4 to 150 breaths/minute
Pressure compensation:	automatic, continuous
Gas compensations:	User selectable O <sub>2</sub> , N <sub>2</sub> O or OFF

**CO<sub>2</sub> (option N-LCM)**

Calibration:	No routine calibration required; automatic self-calibration every 30 ms
Alarms:	adjustable high and low alarm limits for Et/Fi CO <sub>2</sub> and respiration rate
CO <sub>2</sub> sensor weight:	< 18,5 g (excluding cable)
Cable length:	3 meters
Warm-up time:	< 80 seconds from 25 °C / 77 °F
Response time:	100 ms

\*\* ) typical value in conditions 22,5°C, 760 mmHg, CO<sub>2</sub> in balance air, I:E 1:2

**General**

Monitor (WxDxH):	325 x 160 x 210 mm / 12.8 x 6.3 x 8.3"
Battery module (WxDxH):	290 x 150 x 40 mm / 11.4 x 5.9 x 1.6"
Weight:	4.2 kg/9.3 lb.
Weight w/ battery:	6.1 kg/13.5 lb.
Input voltage:	12.5 V DC
Power consumption	17.5... 37 W depending on the options used
Safety standards:	Designed to meet IEC 60601-1, CAN/CSA C22.2 No. 601.1-M90 and UL 2601-1, CE-marking according to Directive 93/42/EEC
Output specifications:	RS-232 computer serial output Defibrillation synchronization signal (According to ANSI/AAMI EC13-1992. Time interval from R peak to sync pulse output ≤ 35 ms.) Nurse Call Analog output, 2 fixed and 2 freely configurable outputs
Printing:	Local printing with laser printer (PCL5), or via network.
Recorder option:	Built-in three channel thermal array recorder.

**Environmental conditions**

Operating temperature:	0 to 40 °C (32 to 104 °F), CO <sub>2</sub> option +5 to 40 °C (41 to 104°F) mainstream sensor +10 to 40 °C (50 to 104 °F) Battery charging temperature 10 to 40 °C (50 to 104 °F)
Storage and transport temperature:	-30 to 70 °C (-22 to 158 °F), -30 to 70 °C (-22 to 158 °F) with CO <sub>2</sub> -30 to 50 °C (-22 to 122 °F) for batteries
Relative humidity:	5 to 95% non-condensing
Atmospheric pressure:	660 to 1060 mbar (500 to 800 mmHg)

For accessories, please refer to the "Accessories" list.  
Specifications subject to change without notice.

**Display**

Display size and type:	8.4" Active Matrix Color TFT LCD
Number of traces:	Up to 4
Display resolution:	640 x 480
Display layout:	User-configurable
Integrated direct function keys, menu key and ComWheel™ for selections and adjustments in menus.	

**Trends**

Graphical:	2, 4, 12 and 24 h
Numerical:	all parameters, sampled every 5 min and after NIBP measurement
Trend cursor:	both in graphical and numerical trends

**Alarms**

- Adjustable high and low alarms for HR, Resp, NIBP, SpO<sub>2</sub> Temp, CO<sub>2</sub> (Et/Fi) and Invasive Pressures Alarm system classified according to priority; visually with color and audio tone coded.
- Central alarm display and adjustment page.
- 10 min graphical mini trends referenced to set alarm limits.
- Automatic alarm limits function; alarm limits automatically calculated from current parameter reading when selected.
- Alarms history displaying 10 latest alarms.
- The maximum alarm delay of the alarm at the monitor signal output to network is 1.1 seconds.
- The invasive pressure alarm delay does not comply with the requirements of the invasive pressure standard IEC 60601-2-34.

**Light Monitor Battery Module (optional) (w/2 battery slots)**

Type:	NiCd battery
Capacity:	Up to 2 hours (1 h/batt) typical on full charge at 23 °C / 73 °F
Recharging:	When connected to line power or DC (N-LPOW)
Charging time:	3.5 h / battery to full capacity

**S/5 Light Monitor Backup Battery (optional)**

Type:	NiCd battery
Capacity:	Up to 30 min typical on full charge at 23 °C / 73 °F
Recharging:	When connected to line power or DC (N-LPOW).
Charging time:	1.5 h / battery to full capacity

**External Power Adapter****N-LPOW**

AC voltage range:	220 to 240 V / 100 to 120 V ~ 50/60 Hz
Allowed AC voltage fluctuations:	100 V -10% to 120 V +10%, 220 V -10% to 240 V +10%

**External Power Adapter**

DC output voltage:	12.5 V and 18.5 V
Protection class:	Class I
Grounding:	Hospital grade

**Option codes****Description****Order code**

S/5 Light Monitor	F-LM1 w/ ECG, Resp, NIBP, SpO <sub>2</sub> , Temp
S/5 Light Monitor	F-LMP1 w/ ECG, Resp, NIBP, SpO <sub>2</sub> , Temp, 2xIBP
Light Monitor Power Adapter	N-LPOW Power adapter, 110/220 V
Light Monitor Battery Module	F-LBAT Battery module w/ two batteries
Light Monitor Recorder	N-LREC Built-in 3-channel thermal array recorder
S/5 Light Monitor CO <sub>2</sub> Option	N-LCM Mainstream CO <sub>2</sub>
Mainstream CO <sub>2</sub> sensor	902300
DataCard Option	N-LDATA
Network Option	N-LNET
DataCard & Network Option	N-LDNET
External Battery Charger w/two batteries	N-LCHGR

### Nurse call and defibrillator synchronization signals

The nurse call signal is generated when the alarm is activated. Alarm silencing suppresses the nurse call signal.

The defibrillator synchronization digital signal is generated by ECG. The pulse will be given on each rising R-wave edge on QRS-complex. The pulse amplitude is 5 V and width is 10 ms. When the def sync signal is active, the signal is set to state 1. After 10 ms the state is set to 0. A new pulse will not be generated before the previous pulse is deactivated.

#### WARNING

#### PATIENT SAFETY:

**Use only cables with shielding against electromagnetic interference.**

**Do not use delayed analog signals for defibrillator and intra-aortic balloon pump synchronization.**

## 23 Accessories

The accessories below are approved and specified for the Light Monitor. Patient accessories designed for use with this device are made of biocompatible materials conforming to requirements of the standard EN 30993 Biological Evaluation of Medical Devices and therefore do not contain toxic ingredients or primary skin irritants. The conformity is based either on laboratory testing or material knowledge and the long history of the materials used.

Please note that some products are not available worldwide. You can check the availability with your local GE Healthcare office or distributor.

#### WARNING

**Use only approved accessories, mounts and defibrillator-proof cables and invasive pressure transducers. Other cables, transducers and accessories may cause a safety hazard, damage the equipment or system, result in increased emissions or decreased immunity of the equipment or system or interfere with the measurement. Protection against cardiac defibrillator discharge is due in part to the accessories for pulse oximetry (SpO<sub>2</sub>), temperature (T) and invasive pressure (P) measurement. Single-use accessories are not designed to be re-used. Re-use may cause a risk of contamination and affect the measurement accuracy.**

### Gas monitoring

#### Mainstream CO<sub>2</sub> accessories

Product name	Order code	Specification	Note
Mainstream CO <sub>2</sub> sensor	902300	Mainstream CO <sub>2</sub> sensor	Use with S/5 Light Monitor (F-LM1, F-LMP1)
Mainstream CO <sub>2</sub> airway adapter	902301 pkg of 10 pcs	Single use mainstream CO <sub>2</sub> airway adapter, adult/pediatric Dead space: 6 ml Connectors: 15F-15M Maximum flow: 120 l/min.	Use with S/5 Light Monitor (F-LM1, F-LMP1)



Product name	Order code	Specification	Note
Mainstream CO <sub>2</sub> airway adapter	902302 pkg of 10 pcs	Single use mainstream CO <sub>2</sub> airway adapter, low dead space Dead space: <1 ml Connectors: 15F-15M Maximum flow: 30 l/min.	Use with S/5 Light Monitor (F-LM1, F-LMP1)
Mainstream CO <sub>2</sub> airway adapter	902304 pkg of 3 pcs	Reusable mainstream CO <sub>2</sub> airway adapter, adult/pediatric Dead space: 6 ml Connectors: 15F-15M Maximum flow: 120 l/min.	Use with S/5 Light Monitor (F-LM1, F-LMP1)

**Calibration gases**

Product name	Order code	Specification	Note
Calibration gas regulator	755534	Regulator for QUICK CAL calibration gas cans	Use with calibration gas, aerosol can 755580
QUICK CAL calibration gas	755580 pkg of 4 cans	QUICK CAL calibration gas, aerosol can Contains: 5.0% CO <sub>2</sub> , Balance air Accuracy: 0.5% relative	Use with regulator 755534
Calibration Check Adapter Kit	902305	CO <sub>2</sub> Calibration Check Adapter and silicon tube	For 755580

**Pulse oximetry sensors**

**Reusable sensors**

Product name	Order code	Specification	Note
OxyTip+ Finger	OXY-F4-N	Cable 4m/13ft	Standard sensor for adults and children.
OxyTip+ Finger	OXY-F-DB	Cable 2m/6.5ft	Standard sensor for adults and children. Cable required.
OxyTip+ Wrap	OXY-W-DB	Cable 2m/6.5ft	Multisite sensor for adults and infants. Cable required.
OxyTip+ Ear	OXY-E-DB	Cable 1 m/3 ft	Multisite sensor for adults and infants. Cable required.

**Cables for reusable sensors**

Product name	Order code	Specification	Note
Sat Sensor Cable	OXY-C1	Cable 1.5 m/5 ft	
	OXY-C3	Cable 3.0 m/10 ft	
Sat Sensor Cable	OXY-C7	Cable 7 m/23 ft	

**Universal sensors (cable required)**

Product name	Order code	Specification	Note
OxyTip+ Finger	OXY-F-UN	1 m/3.3 ft.	
OxyTip+ Wrap	OXY-W-UN	1 m/3.3 ft.	
OxyTip+ Sensitive Skin	OXY-SE-3	1 m/3.3 ft., 3/pkg	

**Single-patient sensors (cable required)**

Product name	Order code	Specification	Note
OxyTip+ Adult/Pediatric	OXY-AP-10	10/pkgt	
OxyTip+ Adult/Pediatric	OXY-AP-25	25/pkg	
OxyTip+ AllFit	OXY-AF-10	10/pkg	

**Cable for universal & single-patient sensors**

Product name	Order code	Specification	Note
Cable	OXY-SL3	3 m/10 ft.	

### ECG cables

NOTE: All Datex-Ohmeda ECG cables can be used for respiration monitoring with Datex-Ohmeda S/5 monitors.

#### ECG trunk cables, IEC color coding

Product name	Order code	Specification	Note
300-Series 3-lead trunk cable, IEC	545305	300-Series 3-lead trunk cable 1.2 m/4 ft, IEC color coding	Requires 300-Series lead set with IEC color coding.
	545300	300-Series 3-lead trunk cable 3.0 m/ 10 ft, IEC color coding	Requires 300-Series lead set with IEC color coding.
	545304	300-Series 3-lead trunk cable 5.0 m/16 ft, IEC color coding	Requires 300-Series lead set with IEC color coding.
300-Series 5-lead trunk cable, IEC	545306	300-Series 5-lead trunk cable 1.2 m/4 ft, IEC color coding	Requires 300-Series lead set with IEC color coding.

#### ECG lead sets, IEC color coding

Product name	Order code	Specification	Note
300-Series 3-lead set, IEC	545315	300-Series 3-lead set with clips, 75 cm/ 30 in, IEC color coding	Detachable leads. Requires 300-Series trunk cable with IEC color coding.
	8001960	300-Series 3-lead set with clips, 1.5 m/60 in, IEC color coding	Detachable leads. Requires 300-Series trunk cable with IEC color coding.
300-Series 5-lead set, IEC	545316	300-Series 5-lead set with clips, 125 cm/ 49 in (leg) and 75 cm/30 in (chest), IEC color coding	Detachable leads. Requires 300-Series trunk cable with IEC color coding.
	8001961	300-Series 5-lead set with clips, 1.5 m/60 in, IEC color coding	Detachable leads. Requires 300-Series trunk cable with IEC color coding.

### ECG trunk cables, AAMI color coding

Product name	Order code	Specification	Note
300-Series 3-lead trunk cable, AAMI	545307	300-Series 3-lead trunk cable 1.2 m/4 ft, AAMI color coding	Requires 300-Series lead set with AAMI color coding.
	545302	300-Series 3-lead trunk cable 3.0 m/ 10 ft, AAMI color coding	Requires 300-Series lead set with AAMI color coding.
300-Series 5-lead trunk cable, AAMI	545308	300-Series 5-lead trunk cable 1.2 m/4 ft, AAMI color coding	Requires 300-Series lead set with AAMI color coding.

#### ECG lead sets, AAMI color coding

Product name	Order code	Specification	Note
300-Series 3-lead set, AAMI	545317	300-Series 3-lead set with clips, 75 cm/ 30 in, AAMI color coding	Detachable leads. Requires 300-Series trunk cable with AAMI color coding.
	8001958	300-Series 3-lead set with clips, 1.5 m/60 in, AAMI color coding	
300-Series 5-lead set, AAMI	545318	300-Series 5-lead set with clips, 125 cm/ 49 in (leg) and 75 cm/30 in (chest), AAMI color coding	Detachable leads. Requires 300-Series trunk cable with AAMI color coding.
	8001959	300-Series 5-lead set with clips, 1.5 m/60 in, AAMI color coding	
300-Series 3-lead set, AAMI	545327	300-Series 3-lead set with snaps, 75 cm / 30 in, AAMI color coding	Detachable leads. Requires 300-Series trunk cable with AAMI color coding.
300-Series 5-lead set, AAMI	545328	300-Series 5-lead set with snaps, 125 cm /49 in (leg) and 75 cm/30 in (chest), AAMI color coding	Detachable leads. Requires 300-Series trunk cable with AAMI color coding.

**ECG replacement clip leads**

Product name	Order code	Specification	Note
300-Series replacement clip lead	545340	300-Series replacement clip lead, red R, 75 cm/30 in	
	545341	300-Series replacement clip lead, green F, 75 cm/30 in	
	545342	300-Series replacement clip lead, yellow L, 75 cm/30 in	
	545343	300-Series replacement clip lead, white C, 75 cm/30 in	
	545344	300-Series replacement clip lead, black LA, 75 cm/30 in	
	545345	300-Series replacement clip lead, brown V, 75 cm/30 in	
	545358	300-Series replacement clip lead, red LL, 75 cm/30 in	
300-Series replacement clip lead	545359	300-Series replacement clip lead, white RA, 75 cm/30 in	
	545346	300-Series replacement clip lead, red LL, 125 cm/49 in	
	545347	300-Series replacement clip lead, green F, 125 cm/49 in	
	545348	300-Series replacement clip lead, black N, 125 cm/49 in	
	545349	300-Series replacement clip lead, green RL, 125 cm/49 in	

**ECG replacement snap leads**

Product name	Order code	Specification	Note
300-Series replacement snap lead	545350	300-Series replacement snap lead, red LL, 75 cm/30 in	
	545351	300-Series replacement snap lead, black LA, 75 cm/30 in	
	545352	300-Series replacement snap lead, white RA, 75 cm/30 in	
	545353	300-Series replacement snap lead, brown V, 75 cm/30 in	
	545354	300-Series replacement snap lead, red LL, 125 cm/49 in	
	545355	300-Series replacement snap lead, green RL, 125 cm/49 in	

**ECG miscellaneous**

Product name	Order code	Specification	Note
Combiner for 300-Series 3-lead set	545390 pkg of 3 pcs	Combiner for 300-Series 3-lead sets	
Combiner for 300-Series 5-lead set	545391 pkg of 3 pcs	Combiner for 300-Series 5-lead sets	
Organizer for 300-Series 3-lead set	545392 pkg of 10 pcs	Organizer for 300-Series 3-lead sets	
Organizer for 300-Series 5-lead set	545393 pkg of 10 pcs	Organizer for 300-Series 5-lead sets	
Bed sheet clip	891192 pkg of 3 pcs	Bed sheet clip	Use with all Datex-Ohmeda ECG cables.

**Compatibility Trunk cables**

Compatibility trunk cables enable use of Multi-Link 3- and 5-leadsets with round connectors.  
 M1020547 in IEC color coding  
 M1020563 in AAMI color coding

**Multi-Link Leadsets with Grabber in IEC color coding**

412682-003	Multi-Link 3-leadwire Set	Grouped, Grabber, 74 cm/29 in.
412682-004	Multi-Link 3-leadwire Set	Grouped, Grabber, 130 cm/51 in.
412681-003	Multi-Link 5-leadwire Set	Grouped, Grabber, 74 cm/29 in.

412681-004	Multi-Link 5-leadwire Set	Grouped, Grabber, 130 cm/51 in.
412681-006	Multi-Link 5-leadwire Set	Grouped, Grabber, Mixed Length - N, F, C 130 cm/51 in., R, L - 74 cm/29 in.
414556-006	Multi-Link 5-Leadwire Set	Individually Replaced - Grabber, Mixed Length - N, F, C 130 cm/51 in., R, L - 74 cm/29 in.

**Multi-Link Leadsets with Snaps in IEC color coding**

411203-003	Multi-Link 3-leadwire Set	Group, Snap, 74 cm/29 in.
411203-004	Multi-Link 3-leadwire Set	Group, Snap, 130 cm/51 in.
411202-003	Multi-Link 5-leadwire Set	Group, Snap, 74 cm/29 in.
411202-004	Multi-Link 5-leadwire Set	Group, Snap, 130 cm/51 in.
411202-006	Multi-Link 5-leadwire Set	Grouped, Snap, Mixed Length - N, F, C 130 cm/51 in., R, L - 74 cm/29 in.
411200-006	Multi-Link 5-Leadwire Set	Individually Replaced, Snap, Mixed Length - N, F, C 130 cm/51 in., R, L, 74 cm/29 in.

**Multi-Link Leadsets with Grabber in AAMI/AHA color coding**

412682-001	Multi-Link 3-leadwire Set	Grouped, Grabber, 74 cm/29 in.
412682-002	Multi-Link 3-leadwire Set	Grouped, Grabber, 130 cm/51 in.
412681-001	Multi-Link 5-leadwire Set	Grouped, Grabber, 74 cm/29 in.
412681-002	Multi-Link 5-leadwire Set	Grouped, Grabber, 130 cm/51 in.
412681-005	Multi-Link 5-leadwire Set	Grouped, Grabber, Mixed Length - RL, LL V 130 cm/51 in., RA, LA - 74 cm/29 in.
414556-005	Multi-Link 5-Leadwire Set	Individually Replaced - Grabber, Mixed Length - RL, LL, V 130 cm/51 in., RA, LA - 74 cm/29 in.

**Multi-Link Leadsets with Snaps in AAMI/AHA color coding**

411203-001	Multi-Link 3-leadwire Set	Group, Snap, 74 cm/29 in.
411203-002	Multi-Link 3-leadwire Set	Group, Snap, 130 cm/51 in.
411202-001	Multi-Link 5-leadwire Set	Group, Snap, 74 cm/29 in.

411202-002	Multi-Link 5-leadwire Set	Group, Snap, 130 cm/51 in.
411202-005	Multi-Link 5-Leadwire Set	Group, Snap, Mixed Length - RL, LL, V 130 cm/51 in, RA, LA- 74 cm/29 in.
411200-005	Multi-Link 5-Leadwire Set	Individually Replaced, Snap, Mixed Length - RL, LL, V 130 cm/51 in., RA, LA - 74 cm/29 in.

**Electrodes**

Product name	Order code	Specification	Note
ECG electrode	572683 pkg of 50 pcs	ECG electrodes, solid gel, Ag/AgCl	Disposable.
Infant ECG electrode	685-0037-00, pkg of 300 sets	Pre-gelled, DIN safety, prewired	Disposable. Connects directly to 300-Series trunk cable.

**Temperature probes**

**Reusable probes**

Product name	Order code	Specification	Note
Skin temperature probe	M1024254	3 m/10 ft	For adults and infants. Can be autoclaved at 121°C/250°F.
Adult general purpose temperature probe	M1024247	3 m/10 ft	Can be autoclaved at 121°C/250°F.
Pediatric general purpose temperature probe	M1024251	3 m/10 ft	Can be autoclaved at 121°C/250°F.

**Disposable probes**

Product name	Order code	Specification	Note
Skin temperature probe	8001642	2.8 m/9 ft	
Central temperature probe 12 F	8001643		
Central temperature probe 9 F	8001644		

Esophageal stetoscope with temp. probe 9 F	8002910		
Esophageal stetoscope with temp. probe 12 F	8002911		
Esophageal stetoscope with temp. probe 18 F	8002908		
Esophageal stetoscope with temp. probe 24F	8002909		
Extension cable for disposable temperature probes	165640	1.3 m/4.3 ft	
	165641	2.8 m/9 ft.	

### NIBP cuffs

#### Latex-free reusable

Product name	Order code	Specification	Note
Reusable cuffs	2754E	Large adult, for arm circumference 33 - 47 cm	Requires black adult hose.
	2753E	Standard adult, for arm circumference 25 - 35 cm	
	2752E	Small adult, for arm circumference 18 - 26 cm	
	2751E	Child, for arm circumference 10 - 19 cm	
	002756	Adult long, for arm circumference 23 - 33 cm	
	002757	Large adult long, for arm circumference 31 - 40 cm	
Reusable infant cuff	2750E	Infant For arm circumference 9 - 14 cm	Requires white infant hose.

### NIBP cuffs, disposable

Product name	Order code	Specification	Note
Soft-Cuf, Infant #3	2523	white, 6 - 11 cm/2.4 - 4.3 in, pkg of 20	Requires white infant hose.
Soft-Cuf, Infant #4	2524	white, 7 - 13 cm/2.8 - 5.1 in, pkg of 20	Requires white infant hose.
Soft-Cuf, Infant #5	2525	white, 8 - 15 cm/3.2 - 5.9 in, pkg of 20	Requires white infant hose.
Classic-Cuf, Infant #3	2628	white, 6 - 11 cm/2.4 - 4.3 in, pkg of 20	Requires white infant hose.
Classic-Cuf, Infant #4	2623	white, 7 - 13 cm/2.8 - 5.1 in, pkg of 20	Requires white infant hose.
Classic-Cuf, Infant #5	2619	white, 8 - 15 cm/3.2 - 5.9 in, pkg of 20	Requires white infant hose.

### NIBP cuff hoses

Product name	Order code	Specification	Note
Adult hose, black	877235	Black, 3 m/10 ft	
	879739	Black, 6 m/20 ft	
Infant hose, white	877514	White, 3 m/10 ft	Do not use with Light Monitor F-LM and F-LMP.
Infant hose, white	890639	White, 6 m/20 ft	Do not use with Light Monitor F-LM and F-LMP.
Plastic connectors	64655	Plastic connectors for upgrading adult NIBP cuffs and hoses	

### Invasive blood pressure transducers

NOTE: Companies like Abbott, Baxter/Edwards, COBE, Beckton-Dickinson and Utah Medical can provide adapter cables for Datex-Ohmeda monitors to be used with disposable transducers from these companies.

**InvBP transducers and cables, reusable**

Product name	Order code	Specification	Note
Reusable InvBP transducer	16576	SensoNor 840, 3 m/10 ft Sensitivity: 50 $\mu$ V/V/cmHg	Requires disposable dome 16578 and flushing kit 16577.
Reusable transducer	165700	Spectramed P10EZ-1, 0.45 m/ 1.5 ft. Sensitivity: 50 $\mu$ V/V/ cmHg	Requires flushing kit 16571 and adapter cable 54586.
Holder for InvBP transducer	16579	Holder for 2 x SensoNor 840 transducers	
Adapter cable	54586	Cable 3.8 m/12 ft	Use with Beckton-Dickinson DTX disposable pressure transducers or Spectramed P10EZ-1.
Adapter cable	875408	Cable 30 cm/1 ft	Use with HP 1290C-type pressure transducers.

**Flushing kits, disposable**

Product name	Order code	Specification	Note
Disposable flushing kit	16577 pkg of 10 kits	Disposable flushing kit for transducer SensoNor 840	Sterile. Each kit includes tubing and one dome.
Disposable dome	16578 pkg of 50 pcs	Disposable dome for transducer SensoNor 840	Sterile.
Disposable flushing kit	16571 pkg of 5 kits	Disposable flushing kit for transducer Spectramed P10EZ-1	

**Interface cables**

**Interface cables for configured monitors**

Product name	Order code	Specification	Note
Light Monitor-Printer cable	894193	Light Monitor, models F-LM1 and F-LMP1 - printer cable	Local laser printer cable (PCL5).

**Mounting elements**

Product name	Order code	Specification	Note
Portable monitor wall mount	572238	Portable Monitor Wall Mount	Requires mounting plate 890915 for Light Monitor. Max. load 27 kg.
Portable monitor roll stand	M1039741	Portable Monitor Roll Stand	Requires mounting plate 890915 for Light Monitor. Includes basket for monitor accessories.
Light monitor mounting plate	890915	Light Monitor Universal Mounting Plate	Mounts Light Monitor to Portable Monitor Wall Mount, Portable Monitor Roll Stand and to a fixed vertical pole within diameter range: 25 - 32 mm (1 - 1.25 in) with maximum load of 7.5 kg (16.5 lbs). Includes mounting plate adapter 572623.
Mounting plate adapter	572623	Mounting plate adapter for Light Monitor	Included in Light Monitor Universal Mounting Plate, 890915.
Light Monitor protective case	737731	Protective case for Datex-Ohmeda Light Monitor	

**Miscellaneous**

Product name	Order code	Specification	Note
Light Monitor battery	896895	Light Monitor Battery Module w/2 batteries, F-LBAT	For Light Monitor. NiCd battery.
Light Monitor data card	M1021735	Light Monitor data card for models F-LM1 and F-LMP1	English. Allows data storage of physiological trends for data continuum.
	M1021736	Light Monitor data card for models F-LM1 and F-LMP1	French. Allows data storage of physiological trends for data continuum.

Product name	Order code	Specification	Note
Dust filter	886841	Dust filter	For Datex-Ohmeda Light Monitor.
Thermal recorder paper	74205 pkg of 20 rolls	Thermal recorder paper - width 50 mm/2 in	

### Accessory kits

8000084	<ul style="list-style-type: none"> <li>- 1 three-lead ECG trunk cable, AAMI color coding (545302)</li> <li>- 1 three-lead set ECG, AAMI color coding (545317)</li> <li>- 1 adult NIBP hose (877235)</li> <li>- 1 adult DURA-CUF ( 2753E)</li> <li>- 1 adult skin temperature probe (16560)</li> <li>- 1 OXY-C3 interconnect cable, 3 m/10 ft. (OXY-C3)</li> <li>- 1 OXY-F-DB interconnect sensor, 2 m/6.5 ft. (OXY-F-DB)</li> </ul>
8000085	<ul style="list-style-type: none"> <li>- 1 three-lead ECG trunk cable, IEC color coding (545300)</li> <li>- 1 three-lead set ECG, IEC color coding (545315)</li> <li>- 1 adult NIBP hose (877235)</li> <li>- 1 adult DURA-CUF ( 2753E)</li> <li>- 1 adult skin temperature probe (16560)</li> <li>- 1 OXY-C3 interconnect cable, 3 m/10 ft. (OXY-C3)</li> <li>- 1 OXY-F-DB interconnect sensor, 2 m/6.5 ft. (OXY-F-DB)</li> </ul>

Index

---

**Index**

---

**A**

- Abbreviations 7
- Accessories 139
- Adjusting
  - alarms 42
  - CO2 measurement 111
  - ECG 80
  - invasive pressures 105
  - monitor settings 51
  - NIBP setup 100
  - pulse oximetry 90
  - Respiration measuring 83
  - screen settings 51
  - temperature setup 93
  - time and date 53
- Alarm indicators 19
- Alarms
  - auto limits 47
  - automatic recording 44
  - categories 39
  - default limits 45
  - indicators 40
  - invasive pressures 108
  - messages 117
  - setup 42
  - silencing 41
  - smart start 40
  - sources 44
  - turning off 41
- Applying electrodes
  - ECG
    - electrodes 77
- Auto alarm limits 47
- Autocycle of NIBP 98
- Automatic alarm recording 44

---

**B**

- Backup Battery 29

- Batteries 29
  - charging 29
  - maintenance 30
  - removing 29
  - storing and disposing 31
- Battery alarms 30
- Battery Module 29
- Bed-to-bed communication 74

---

**C**

- Calibration check 101
  - CO2 112
- Carbon dioxide 109
- Cautions 11
- Changing patients 25
- Changing trend setup 66
- Chapter icons 6
- Checklist 113
- Cleaning 33
  - CO2 109
    - calibration check 112
- CO2 adjustments 111
- ComWheel 19, 21
- Connectors
  - for network 20
  - for parameter measurement 22
  - for printer 20
- Continuous NIBP measurement 99
- Controls 21

---

**D**

- Data management 67
- DataCard 74
- DataCard slot 19
- Date 53
- Default limits of alarms 45
- Default settings 54
- Defibrillator synchronization 138
- Digit fields 53
- Disinfecting 34
- Dust filter 20, 34



**E**

- ECG 77
  - adjustments 80
  - electrode coding 78
  - placing electrodes 78
  - selecting lead 79
- ECG trunk cable selection 79
- Electrical Power Adapter 17
- Erasing trend data 66
- ESD precautionary procedures 16
- ESD training 16

**G**

- Gas concentration 112
- General specifications 129
- Graphic trend pages 62

**H**

- Handle 19

**I**

- Indicators
  - alarms 40
  - battery 29
- Information messages 117
- Install/Service menu 54
- Installation 15
  - printer 72
- Invasive blood pressure 103
- Invasive pressure labels 106

**K**

- Keys 21

**L**

- Labeling the invasive line 106
- Limitations
  - of pulse oximetry measurement 89
  - of respiration measuring 84

**M**

- Mainstream CO2 109
- Maintenance 113
- Menus 26
- Monitor setup 51
- Monitoring 25
- Monitoring ECG 77
- Monitor-to-Monitor communication 74
- Mounting attachment 20

**N**

- Networking 73
- NIBP 95
  - adjustments 100
  - calibration check 101
  - cuffs 95
- Non-invasive blood pressure 95
- Nurse call 138

**P**

- Pacemaker patients 82
- Paper for recorder 71
- Partial pressure 112
- Patient data 67
- Placing electrodes 78
- Points to note 12
- Printer connector 20
- Printer installation 72
- Printing 69, 71
- Pulse oximetry 87
  - alarms 91
  - setup 90

**R**

- Recorder paper replacement 71
- Recording 69
- Regular checks 36
- Replacing recorder paper 71
- Respiration 83
  - measuring principle 85

**S**

- Safety check 36
- Screen setup 51
- Selecting ECG lead 79
- Selecting NIBP cuffs 95
- Selecting numerical display fields
  - Adjusting
    - numerical fields 53
- Selecting pulse oximetry sensor
  - Pulse oximetry
    - sensors 88
- Selecting waveforms
  - Waveforms
    - setting up 52
- Setting time & date 53
- Setup
  - invasive pressure 105
- Signals for nurse call and defibrillator synchronization 138
- Silencing alarms 41
- Smart start alarms 40
- Software safety check 36
- Specifications 129
- Starting 25
- STAT 99
- Sterilization 34
- Symbols
  - chapter icons 6
  - on the equipment 2
  - used in this manuals 6

**T**

- Temperature 93
  - setup 93
- Time 53
- Traces see waveforms 52
- Trends
  - erasing 66
  - numerical 64
  - setting up 66
- Trends, graphic 62

- Triggers of alarms 44
- Troubleshooting 127
- Trunk cable 79
- Turning audible alarms off/on 41

**U**

- Unpacking 15

**V**

- Venous stasis 99
- Viewing graphic trends 62
- Viewing numerical trend 64

**W**

- Warnings 9

**Z**

- Zeroing transducer 104

## Light Monitor Battery Module Installation Guide

Applies to Light Monitor Models F-LM, F-LMP, F-LM1, F-LMP1, F-SOLO and F-SOLOP

Install the Light Monitor Battery Module, F-LBAT, in the following way:

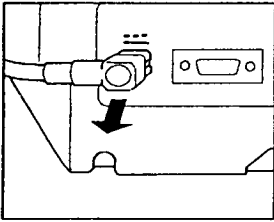

Turn the monitor off and remove the Power Adapter.

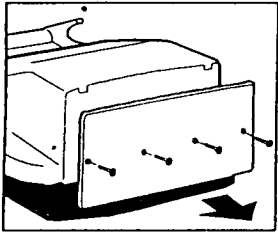

Place the monitor front side down on the table, use soft material between the table and the monitor. Loosen the four screws in the bottom plate of the monitor and pull the plate out of the monitor.

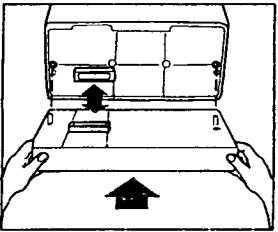

Place empty module frame under the monitor so that the D-connectors match. Tighten the four screws and lift the monitor up to the normal position.

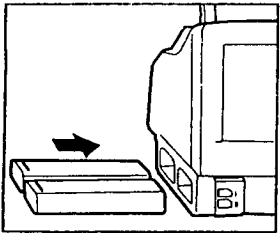

Insert the batteries into the battery slots in the battery frame.

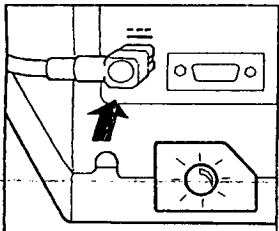

Connect the monitor to the mains power. Verify that one of the battery charge status leds is blinking or both leds are continuously lit.

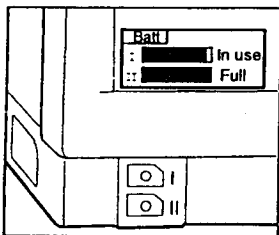

Turn the monitor on. Wait for three minutes. Verify that the battery status is displayed and no error messages appear. Disconnect the monitor from the mains power and verify that the monitor operates with both batteries. To do this, test one battery at a time.

Charge the batteries full before using the monitor.